

Mitsubishi Programmable Controller

**MELSEC iQ-R**  
series

# MELSEC iQ-R High-Speed Counter Module User's Manual (Startup)

---

-RD62P2  
-RD62P2E  
-RD62D2



# SAFETY PRECAUTIONS



---

(Read these precautions before using this product.)

Before using this product, please read this manual and the relevant manuals carefully and pay full attention to safety to handle the product correctly.

The precautions given in this manual are concerned with this product only. For the safety precautions of the programmable controller system, refer to the MELSEC iQ-R Module Configuration Manual.

In this manual, the safety precautions are classified into two levels: "⚠ WARNING" and "⚠ CAUTION".

 <b>WARNING</b>	Indicates that incorrect handling may cause hazardous conditions, resulting in death or severe injury.
 <b>CAUTION</b>	Indicates that incorrect handling may cause hazardous conditions, resulting in minor or moderate injury or property damage.

Under some circumstances, failure to observe the precautions given under "⚠ CAUTION" may lead to serious consequences.

Observe the precautions of both levels because they are important for personal and system safety.

Make sure that the end users read this manual and then keep the manual in a safe place for future reference.

## [Design Precautions]

---

### **WARNING**

---

- Configure safety circuits external to the programmable controller to ensure that the entire system operates safely even when a fault occurs in the external power supply or the programmable controller. Failure to do so may result in an accident due to an incorrect output or malfunction.
    - (1) Emergency stop circuits, protection circuits, and protective interlock circuits for conflicting operations (such as forward/reverse rotations or upper/lower limit positioning) must be configured external to the programmable controller.
    - (2) When the programmable controller detects an abnormal condition, it stops the operation and all outputs are:
      - Turned off if the overcurrent or overvoltage protection of the power supply module is activated.
      - Held or turned off according to the parameter setting if the self-diagnostic function of the CPU module detects an error such as a watchdog timer error.
    - (3) All outputs may be turned on if an error occurs in a part, such as an I/O control part, where the CPU module cannot detect any error. To ensure safety operation in such a case, provide a safety mechanism or a fail-safe circuit external to the programmable controller. For a fail-safe circuit example, refer to "General Safety Requirements" in the MELSEC iQ-R Module Configuration Manual.
    - (4) Outputs may remain on or off due to a failure of a component such as a relay and transistor in an output circuit. Configure an external circuit for monitoring output signals that could cause a serious accident.
  - In an output circuit, when a load current exceeding the rated current or an overcurrent caused by a load short-circuit flows for a long time, it may cause smoke and fire. To prevent this, configure an external safety circuit, such as a fuse.
  - Configure a circuit so that the programmable controller is turned on first and then the external power supply. If the external power supply is turned on first, an accident may occur due to an incorrect output or malfunction.
  - For the operating status of each station after a communication failure, refer to manuals relevant to the network. Incorrect output or malfunction due to a communication failure may result in an accident.
  - When connecting an external device with a CPU module or intelligent function module to modify data of a running programmable controller, configure an interlock circuit in the program to ensure that the entire system will always operate safely. For other forms of control (such as program modification, parameter change, forced output, or operating status change) of a running programmable controller, read the relevant manuals carefully and ensure that the operation is safe before proceeding. Improper operation may damage machines or cause accidents.
-

## [Design Precautions]

---

### **WARNING**

- Especially, when a remote programmable controller is controlled by an external device, immediate action cannot be taken if a problem occurs in the programmable controller due to a communication failure. To prevent this, configure an interlock circuit in the program, and determine corrective actions to be taken between the external device and CPU module in case of a communication failure.
  - Do not write any data to the "system area" and "write-protect area" of the buffer memory in the module. Also, do not use any "use prohibited" signals as an output signal from the CPU module to each module. Doing so may cause malfunction of the programmable controller system. For the "system area", "write-protect area", and the "use prohibited" signals, refer to the user's manual for the module used.
  - If a communication cable is disconnected, the network may be unstable, resulting in a communication failure of multiple stations. Configure an interlock circuit in the program to ensure that the entire system will always operate safely even if communications fail. Failure to do so may result in an accident due to an incorrect output or malfunction.
  - To maintain the safety of the programmable controller system against unauthorized access from external devices via the network, take appropriate measures. To maintain the safety against unauthorized access via the Internet, take measures such as installing a firewall.
  - Outputs may remain on or off due to a failure of a transistor for external output. Configure an external circuit for monitoring output signals that could cause a serious accident.
- 

## [Design Precautions]

---

### **CAUTION**

- During control of an inductive load such as a lamp, heater, or solenoid valve, a large current (approximately ten times greater than normal) may flow when the output is turned from off to on. Therefore, use a module that has a sufficient current rating.
  - After the CPU module is powered on or is reset, the time taken to enter the RUN status varies depending on the system configuration, parameter settings, and/or program size. Design circuits so that the entire system will always operate safely, regardless of the time.
  - Do not power off the programmable controller or reset the CPU module while the setting values in the buffer memory are being written to the flash ROM in the module. Doing so will make the data in the flash ROM undefined. The values need to be set in the buffer memory and written to the flash ROM again. Doing so also can cause malfunction or failure of the module.
  - When changing the operating status of the CPU module from external devices (such as the remote RUN/STOP functions), select "Do Not OPEN in Program" for "Open Method Setting" in the module parameters. If "OPEN in Program" is selected, an execution of the remote STOP function causes the communication line to close. Consequently, the CPU module cannot reopen the line, and external devices cannot execute the remote RUN function.
  - Do not install the control lines or communication cables together with the main circuit lines or power cables. Keep a distance of 150mm or more between them. Failure to do so may result in malfunction due to noise.
-

## [Installation Precautions]

---

### **WARNING**

- Shut off the external power supply (all phases) used in the system before mounting or removing the module. Failure to do so may result in electric shock or cause the module to fail or malfunction.
- 

## [Installation Precautions]

---

### **CAUTION**

- Use the programmable controller in an environment that meets the general specifications in the Safety Guidelines included with the base unit. Failure to do so may result in electric shock, fire, malfunction, or damage to or deterioration of the product.
  - To mount a module, place the concave part(s) located at the bottom onto the guide(s) of the base unit, and push in the module until the hook(s) located at the top snaps into place. Incorrect interconnection may cause malfunction, failure, or drop of the module.
  - When using the programmable controller in an environment of frequent vibrations, fix the module with a screw.
  - Tighten the screws within the specified torque range. Undertightening can cause drop of the screw, short circuit, or malfunction. Overtightening can damage the screw and/or module, resulting in drop, short circuit, or malfunction.
  - When using an extension cable, connect it to the extension cable connector of the base unit securely. Check the connection for looseness. Poor contact may cause malfunction.
  - When using an SD memory card, fully insert it into the SD memory card slot. Check that it is inserted completely. Poor contact may cause malfunction.
  - Securely insert an extended SRAM cassette into the cassette connector of the CPU module. After insertion, close the cassette cover and check that the cassette is inserted completely. Poor contact may cause malfunction.
  - Do not directly touch any conductive parts and electronic components of the module, SD memory card, extended SRAM cassette, or connector. Doing so can cause malfunction or failure of the module.
- 

## [Wiring Precautions]

---

### **WARNING**

- Shut off the external power supply (all phases) used in the system before installation and wiring. Failure to do so may result in electric shock or cause the module to fail or malfunction.
  - After installation and wiring, attach the included terminal cover to the module before turning it on for operation. Failure to do so may result in electric shock.
-

## [Wiring Precautions]

---

### CAUTION

- Individually ground the FG and LG terminals of the programmable controller with a ground resistance of 100 ohms or less. Failure to do so may result in electric shock or malfunction.
  - Use applicable solderless terminals and tighten them within the specified torque range. If any spade solderless terminal is used, it may be disconnected when the terminal screw comes loose, resulting in failure.
  - Check the rated voltage and signal layout before wiring to the module, and connect the cables correctly. Connecting a power supply with a different voltage rating or incorrect wiring may cause fire or failure.
  - Connectors for external devices must be crimped or pressed with the tool specified by the manufacturer, or must be correctly soldered. Incomplete connections may cause short circuit, fire, or malfunction.
  - Securely connect the connector to the module. Poor contact may cause malfunction.
  - Do not install the control lines or communication cables together with the main circuit lines or power cables. Keep a distance of 100mm or more between them. Failure to do so may result in malfunction due to noise.
  - Place the cables in a duct or clamp them. If not, dangling cable may swing or inadvertently be pulled, resulting in damage to the module or cables or malfunction due to poor contact. Do not clamp the extension cables with the jacket stripped.
  - Check the interface type and correctly connect the cable. Incorrect wiring (connecting the cable to an incorrect interface) may cause failure of the module and external device.
  - Tighten the terminal screws or connector screws within the specified torque range. Undertightening can cause drop of the screw, short circuit, fire, or malfunction. Overtightening can damage the screw and/or module, resulting in drop, short circuit, fire, or malfunction.
  - When disconnecting the cable from the module, do not pull the cable by the cable part. For the cable with connector, hold the connector part of the cable. For the cable connected to the terminal block, loosen the terminal screw. Pulling the cable connected to the module may result in malfunction or damage to the module or cable.
  - Prevent foreign matter such as dust or wire chips from entering the module. Such foreign matter can cause a fire, failure, or malfunction.
  - A protective film is attached to the top of the module to prevent foreign matter, such as wire chips, from entering the module during wiring. Do not remove the film during wiring. Remove it for heat dissipation before system operation.
  - Programmable controllers must be installed in control panels. Connect the main power supply to the power supply module in the control panel through a relay terminal block. Wiring and replacement of a power supply module must be performed by qualified maintenance personnel with knowledge of protection against electric shock. For wiring, refer to the MELSEC iQ-R Module Configuration Manual.
  - For Ethernet cables to be used in the system, select the ones that meet the specifications in the user's manual for the module used. If not, normal data transmission is not guaranteed.
  - Do not install the control lines or communication cables together with the main circuit lines or power cables. Keep a distance of 150mm or more between them. Failure to do so may result in malfunction due to noise.
  - Ground the shield cable on the encoder side (relay box) with a ground resistance of 100 ohm or less. Failure to do so may cause malfunction.
-

## [Startup and Maintenance Precautions]

---

### **WARNING**

- Do not touch any terminal while power is on. Doing so will cause electric shock or malfunction.
  - Correctly connect the battery connector. Do not charge, disassemble, heat, short-circuit, solder, or throw the battery into the fire. Also, do not expose it to liquid or strong shock. Doing so will cause the battery to produce heat, explode, ignite, or leak, resulting in injury and fire.
  - Shut off the external power supply (all phases) used in the system before cleaning the module or retightening the terminal screws, connector screws, or module fixing screws. Failure to do so may result in electric shock.
- 

## [Startup and Maintenance Precautions]

---

### **CAUTION**

- When connecting an external device with a CPU module or intelligent function module to modify data of a running programmable controller, configure an interlock circuit in the program to ensure that the entire system will always operate safely. For other forms of control (such as program modification, parameter change, forced output, or operating status change) of a running programmable controller, read the relevant manuals carefully and ensure that the operation is safe before proceeding. Improper operation may damage machines or cause accidents.
  - Especially, when a remote programmable controller is controlled by an external device, immediate action cannot be taken if a problem occurs in the programmable controller due to a communication failure. To prevent this, configure an interlock circuit in the program, and determine corrective actions to be taken between the external device and CPU module in case of a communication failure.
  - Do not disassemble or modify the modules. Doing so may cause failure, malfunction, injury, or a fire.
  - Use any radio communication device such as a cellular phone or PHS (Personal Handy-phone System) more than 25cm away in all directions from the programmable controller. Failure to do so may cause malfunction.
  - Shut off the external power supply (all phases) used in the system before mounting or removing the module. Failure to do so may cause the module to fail or malfunction.
  - Tighten the screws within the specified torque range. Undertightening can cause drop of the component or wire, short circuit, or malfunction. Overtightening can damage the screw and/or module, resulting in drop, short circuit, or malfunction.
  - After the first use of the product, do not mount/remove the module to/from the base unit, and the terminal block to/from the module, and do not insert/remove the extended SRAM cassette to/from the CPU module more than 50 times (IEC 61131-2 compliant) respectively. Exceeding the limit may cause malfunction.
  - After the first use of the product, do not insert/remove the SD memory card to/from the CPU module more than 500 times. Exceeding the limit may cause malfunction.
  - Do not touch the metal terminals on the back side of the SD memory card. Doing so may cause malfunction or failure of the module.
  - Do not touch the integrated circuits on the circuit board of an extended SRAM cassette. Doing so may cause malfunction or failure of the module.
  - Do not drop or apply shock to the battery to be installed in the module. Doing so may damage the battery, causing the battery fluid to leak inside the battery. If the battery is dropped or any shock is applied to it, dispose of it without using.
-



## [Startup and Maintenance Precautions]

---

### CAUTION

- Startup and maintenance of a control panel must be performed by qualified maintenance personnel with knowledge of protection against electric shock. Lock the control panel so that only qualified maintenance personnel can operate it.
  - Before handling the module, touch a conducting object such as a grounded metal to discharge the static electricity from the human body. Failure to do so may cause the module to fail or malfunction.
- 

## [Operating Precautions]

---

### CAUTION

- When changing data and operating status, and modifying program of the running programmable controller from an external device such as a personal computer connected to an intelligent function module, read relevant manuals carefully and ensure the safety before operation. Incorrect change or modification may cause system malfunction, damage to the machines, or accidents.
  - Do not power off the programmable controller or reset the CPU module while the setting values in the buffer memory are being written to the flash ROM in the module. Doing so will make the data in the flash ROM undefined. The values need to be set in the buffer memory and written to the flash ROM again. Doing so can cause malfunction or failure of the module.
- 

## [Disposal Precautions]

---

### CAUTION

- When disposing of this product, treat it as industrial waste.
  - When disposing of batteries, separate them from other wastes according to the local regulations. For details on battery regulations in EU member states, refer to the MELSEC iQ-R Module Configuration Manual.
- 

## [Transportation Precautions]

---

### CAUTION

- When transporting lithium batteries, follow the transportation regulations. For details on the regulated models, refer to the MELSEC iQ-R Module Configuration Manual.
  - The halogens (such as fluorine, chlorine, bromine, and iodine), which are contained in a fumigant used for disinfection and pest control of wood packaging materials, may cause failure of the product. Prevent the entry of fumigant residues into the product or consider other methods (such as heat treatment) instead of fumigation. The disinfection and pest control measures must be applied to unprocessed raw wood.
-

# CONDITIONS OF USE FOR THE PRODUCT

---

(1) Mitsubishi programmable controller ("the PRODUCT") shall be used in conditions;

- i) where any problem, fault or failure occurring in the PRODUCT, if any, shall not lead to any major or serious accident; and
- ii) where the backup and fail-safe function are systematically or automatically provided outside of the PRODUCT for the case of any problem, fault or failure occurring in the PRODUCT.

(2) The PRODUCT has been designed and manufactured for the purpose of being used in general industries.

MITSUBISHI SHALL HAVE NO RESPONSIBILITY OR LIABILITY (INCLUDING, BUT NOT LIMITED TO ANY AND ALL RESPONSIBILITY OR LIABILITY BASED ON CONTRACT, WARRANTY, TORT, PRODUCT LIABILITY) FOR ANY INJURY OR DEATH TO PERSONS OR LOSS OR DAMAGE TO PROPERTY CAUSED BY the PRODUCT THAT ARE OPERATED OR USED IN APPLICATION NOT INTENDED OR EXCLUDED BY INSTRUCTIONS, PRECAUTIONS, OR WARNING CONTAINED IN MITSUBISHI'S USER, INSTRUCTION AND/OR SAFETY MANUALS, TECHNICAL BULLETINS AND GUIDELINES FOR the PRODUCT.

("Prohibited Application")

Prohibited Applications include, but not limited to, the use of the PRODUCT in;

- Nuclear Power Plants and any other power plants operated by Power companies, and/or any other cases in which the public could be affected if any problem or fault occurs in the PRODUCT.
- Railway companies or Public service purposes, and/or any other cases in which establishment of a special quality assurance system is required by the Purchaser or End User.
- Aircraft or Aerospace, Medical applications, Train equipment, transport equipment such as Elevator and Escalator, Incineration and Fuel devices, Vehicles, Manned transportation, Equipment for Recreation and Amusement, and Safety devices, handling of Nuclear or Hazardous Materials or Chemicals, Mining and Drilling, and/or other applications where there is a significant risk of injury to the public or property.

Notwithstanding the above, restrictions Mitsubishi may in its sole discretion, authorize use of the PRODUCT in one or more of the Prohibited Applications, provided that the usage of the PRODUCT is limited only for the specific applications agreed to by Mitsubishi and provided further that no special quality assurance or fail-safe, redundant or other safety features which exceed the general specifications of the PRODUCTS are required. For details, please contact the Mitsubishi representative in your region.

# INTRODUCTION

---

Thank you for purchasing the Mitsubishi MELSEC iQ-R series programmable controllers.

This manual describes the performance specifications, procedures before operation, wiring, and operation examples of the relevant products listed below.

Before using this product, please read this manual and the relevant manuals carefully and develop familiarity with the functions and performance of the MELSEC iQ-R series programmable controller to handle the product correctly.

When applying the program examples provided in this manual to an actual system, ensure the applicability and confirm that it will not cause system control problems.

Please make sure that the end users read this manual.

---

## **Point**

Unless otherwise specified, this manual provides program examples in which the I/O numbers of X/Y0 to X/YF are assigned to the high-speed counter module. Assign I/O numbers when applying the program examples to an actual system. For I/O number assignment, refer to the following.

 MELSEC iQ-R Module Configuration Manual

---

## **Relevant products**

RD62P2, RD62P2E, RD62D2

# COMPLIANCE WITH EMC AND LOW VOLTAGE DIRECTIVES

---

## Method of ensuring compliance

To ensure that Mitsubishi programmable controllers maintain EMC and Low Voltage Directives when incorporated into other machinery or equipment, certain measures may be necessary. Please refer to one of the following manuals.

- MELSEC iQ-R Module Configuration Manual
- Safety Guidelines (This manual is included with the base unit.)

The CE mark on the side of the programmable controller indicates compliance with EMC and Low Voltage Directives.

## Additional measures

To ensure that this product maintains EMC and Low Voltage Directives, please refer to one of the following manuals.

- MELSEC iQ-R Module Configuration Manual
- Safety Guidelines (This manual is included with the base unit.)

# CONTENTS

SAFETY PRECAUTIONS .....	1
CONDITIONS OF USE FOR THE PRODUCT .....	8
INTRODUCTION .....	9
COMPLIANCE WITH EMC AND LOW VOLTAGE DIRECTIVES .....	10
RELEVANT MANUALS .....	12
TERMS .....	12
PERIPHERALS .....	13
<b>CHAPTER 1 PART NAMES</b> .....	<b>14</b>
<b>CHAPTER 2 SPECIFICATIONS</b> .....	<b>16</b>
2.1 Performance Specifications .....	16
Relation between the input waveform and the phase difference of A phase pulse and B phase pulse .....	20
<b>CHAPTER 3 FUNCTION LIST</b> .....	<b>22</b>
<b>CHAPTER 4 PROCEDURES BEFORE OPERATION</b> .....	<b>24</b>
<b>CHAPTER 5 INSTALLATION AND WIRING</b> .....	<b>26</b>
5.1 Wiring .....	26
Wiring precautions .....	26
Connectors for external devices .....	28
Interface with external devices .....	29
Connectable encoders .....	33
5.2 Examples of Wiring Between the High-Speed Counter Module and an Encoder .....	34
5.3 Examples of Wiring Between a Controller and External Input Terminals .....	37
5.4 Examples of Wiring with External Output Terminals .....	40
<b>CHAPTER 6 OPERATION EXAMPLES</b> .....	<b>42</b>
6.1 Programming Procedure .....	42
6.2 Program Examples .....	43
<b>APPENDIX</b> .....	<b>50</b>
Appendix 1 External Dimensions .....	50
<b>INDEX</b> .....	<b>52</b>
REVISIONS .....	54
WARRANTY .....	55
TRADEMARKS .....	56

# RELEVANT MANUALS

## User's manuals relevant to the module

Manual name [manual number]	Description	Available form
MELSEC iQ-R High-Speed Counter Module User's Manual (Startup) [SH-081239ENG] (this manual)	Performance specifications, procedures before operation, wiring, and operation examples of the high-speed counter module	Print book e-Manual PDF
MELSEC iQ-R High-Speed Counter Module User's Manual (Application) [SH-081241ENG]	Functions, parameter settings, troubleshooting, I/O signals, and buffer memory of the high-speed counter module	Print book e-Manual PDF

This manual does not include detailed information on the following:

- General specifications
- Applicable CPU modules and the number of mountable modules
- Installation

For details, refer to the following.

 MELSEC iQ-R Module Configuration Manual

This manual does not include information on the module function blocks.

For details, refer to the Function Block Reference for the module used.

### Point

e-Manual refers to the Mitsubishi FA electronic book manuals that can be browsed using a dedicated tool.

e-Manual has the following features:

- Required information can be cross-searched in multiple manuals.
- Other manuals can be accessed from the links in the manual.
- The hardware specifications of each part can be found from the product figures.
- Pages that users often browse can be bookmarked.

## TERMS

Unless otherwise specified, this manual uses the following terms.

Term	Description
Buffer memory	A memory in an intelligent module for storing data (such as setting values and monitored values) to be transferred to the CPU module
Engineering tool	Another term for GX Works3
Global label	A label that is valid for all the program data when multiple program data are created in the project. The global label has two types: a module specific label (module label), which is generated automatically by GX Works3, and an optional label, which can be created for any specified device.
GX Works3	The product name of the software package for the MELSEC programmable controllers
High-speed counter module	The abbreviation for the MELSEC iQ-R series high-speed counter module
Module label	A label that represents one of memory areas (I/O signals and buffer memory areas) specific to each module in a given character string. For the module used, GX Works3 automatically generates this label, which can be used as a global label.

# PERIPHERALS

---

The following figure shows the peripherals when the high-speed counter module is used.

High-speed counter module

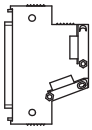

Connector

# 1 PART NAMES

This chapter describes the part names of the high-speed counter module.

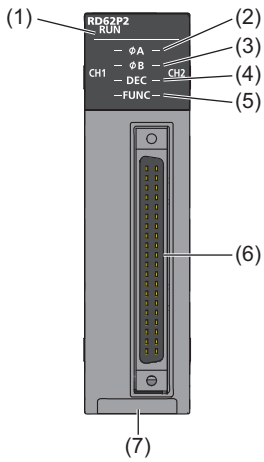

No.	Name	Description
(1)	RUN LED	Indicates the operating status. On: In operation Flashing (400ms cycles): Selected as a module for the online module change Off: 5V power supply interrupted or module replacement allowed in the process of the online module change
(2)	ΦA LED	On: Voltage is being applied to the phase A pulse input terminal.
(3)	ΦB LED	On: Voltage is being applied to the phase B pulse input terminal.
(4)	DEC. LED	On: Counter is performing down count.
(5)	FUNC. LED	On: Voltage is being applied to the function start input terminal.
(6)	Connector for external devices (40 pins)	A connector for connecting an encoder and a controller. For the signal layout, refer to the following. (Page 29 Interface with external devices)
(7)	Production information marking	Shows the product information (16 digits) of the module.





# 2 SPECIFICATIONS

This chapter describes the performance specifications.

## 2.1 Performance Specifications

This section describes the performance specifications of the high-speed counter modules.

### RD62P2 (DC input sink output type), RD62P2E (DC input source output type)

Item		Specifications		
Counting speed switch setting <sup>*1</sup>		200kpps (100k to 200kpps)	100kpps (10k to 100kpps)	10kpps (10kpps or less)
Number of channels		2 channels		
Count input signal	Phase	1-phase input (multiple of 1/multiple of 2), 2-phase input (multiple of 1/multiple of 2/multiple of 4), CW/CCW input		
	Signal level ( $\phi A$ , $\phi B$ )	2 to 5mA at 5/12/24VDC		
Counter	Counting speed (maximum) <sup>*2</sup>	200kpps	100kpps	10kpps
	Counting range	32-bit signed binary value (-2147483648 to 2147483647)		
	Type	UP/DOWN preset counter + Ring counter functions		
Coincidence output	Comparison range	32-bit signed binary value		
	Comparison result	Set value < Count value, Set value = Count value, Set value > Count value		
External input	Preset	7 to 10mA at 5/12/24VDC		
	Function-start			
	Digital filter	0ms, 0.1ms, 1ms, 10ms		
Pulse measurement	Measurement item	Pulse width (ON width/OFF width/rise to rise/fall to fall)		
	Measurement resolution	100ns		
	Number of measurement points	1 point/channel		
External output	Coincidence output	RD62P2	Transistor (sink type) output, 2 points/channel 12/24VDC, 0.5A/point, 2A/common	
		RD62P2E	Transistor (source type) output, 2 points/channel 12/24VDC, 0.1A/point, 0.4A/common	
PWM output	Output frequency range	DC to 200kHz maximum		
	Duty ratio	The cycle time and ON time can be set in increments of 0.1 $\mu$ s.		
	Number of output points	2 points/channel		
Number of occupied I/O points		16 points (I/O assignment: Intelligent 16 points)		
Internal current consumption (5VDC)	RD62P2	0.11A		
	RD62P2E	0.20A		
External dimensions	Height	106mm		
	Width	27.8mm		
	Depth	110mm		
Weight	RD62P2	0.11kg		
	RD62P2E	0.12kg		

\*1 Set the counting speed in the counting speed setting of Basic setting.

\*2 The counting speed is affected by the pulse rise/fall time. A count can be performed with the following counting speed. Note that counting pulses of which the rise/fall time is long may result in an incorrect count.

Counting speed switch setting	200kpps	100kpps	10kpps
Rise/fall time	Both 1 and 2-phase inputs		
t = 1.25µs or less	200kpps	100kpps	10kpps
t = 2.5µs or less	100kpps	100kpps	10kpps
t = 25µs or less	-	10kpps	10kpps
t = 500µs or less	-	-	500pps

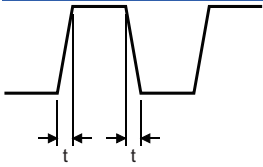

## RD62D2 (differential input sink output type)

Item		Specifications							
Counting speed switch setting <sup>*1</sup>	In multiple of 1	-	-	2Mpps (1M to 2Mpps)	1Mpps (500k to 1Mpps)	500kpps (200k to 500kpps)	200kpps (100k to 200kpps)	100kpps (10k to 100kpps)	10kpps (10kpps or less)
	In multiple of 2	-	4Mpps (2M to 4Mpps)						
	In multiple of 4	8Mpps (4M to 8Mpps)							
Number of channels		2 channels							
Count input signal	Phase	1-phase input (multiple of 1/multiple of 2), 2-phase input (multiple of 1/multiple of 2/multiple of 4), CW/CCW input							
	Signal level ( $\phi A$ , $\phi B$ )	EIA Standards RS-422-A, differential line driver level (AM26LS31 [manufactured by Texas Instruments] or equivalent)							
Counter	Counting speed (maximum) <sup>*2</sup>	8Mpps	4Mpps	2Mpps	1Mpps	500kpps	200kpps	100kpps	10kpps
	Counting range	32-bit signed binary value (-2147483648 to 2147483647)							
	Type	UP/DOWN preset counter + Ring counter functions							
Coincidence output	Comparison range	32-bit signed binary value							
	Comparison result	Set value < Count value, Set value = Count value, Set value > Count value							
External input	Preset	7 to 10mA at 5/12/24VDC (EIA Standard RS-422-A differential line driver can be connected.)							
	Function-start								
	Digital filter	0ms, 0.1ms, 1ms, 10ms							
Pulse measurement	Measurement item	Pulse width (ON width/OFF width/rise to rise/fall to fall)							
	Measurement resolution	100ns							
	Number of measurement points	1 point/channel							
External output	Coincidence output	Transistor (sink type) output, 2 points/channel 12/24VDC, 0.5A/point, 2A/common							
PWM output	Output frequency range	DC to 200kHz maximum							
	Duty ratio	The cycle time and ON time can be set in increments of 0.1 $\mu$ s.							
	Number of output points	2 points/channel							
Number of occupied I/O points		16 points (I/O assignment: Intelligent 16 points)							
Internal current consumption (5VDC)		0.17A							
External dimensions	Height	106mm							
	Width	27.8mm							
	Depth	110mm							
Weight		0.12kg							

\*1 Set the counting speed in the counting speed setting of Basic setting.

\*2 The counting speed is affected by the pulse rise/fall time. A count can be performed with the following counting speed. Note that counting pulses of which the rise/fall time is long may result in an incorrect count.

Counting speed switch setting	8Mpps 4Mpps 2Mpps	1Mpps	500kpps	200kpps	100kpps	10kpps
Rise/fall time	Both 1 and 2-phase inputs					
t = 0.125 $\mu$ s or less	2Mpps	1Mpps	500kpps	200kpps	100kpps	10kpps
t = 0.25 $\mu$ s or less	1Mpps	1Mpps	500kpps	200kpps	100kpps	10kpps
t = 0.5 $\mu$ s or less	-	500kpps	500kpps	200kpps	100kpps	10kpps
t = 1.25 $\mu$ s or less	-	-	200kpps	200kpps	100kpps	10kpps
t = 2.5 $\mu$ s or less	-	-	-	100kpps	100kpps	10kpps
t = 25 $\mu$ s or less	-	-	-	-	10kpps	10kpps
t = 500 $\mu$ s or less	-	-	-	-	-	500pps

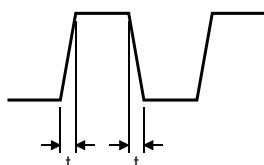

## Minimum count pulse cycle and phase difference

The following table lists the minimum count pulse cycle and phase difference for setting each pulse input mode and counting speed.

For details on pulse input mode, refer to the following.

 MELSEC iQ-R High-Speed Counter Module User's Manual (Application)

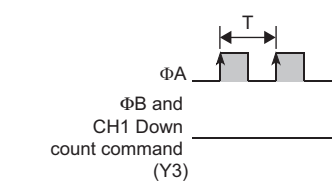
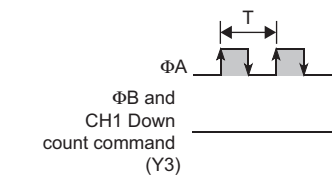
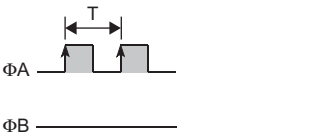
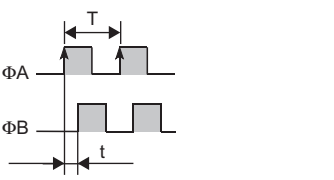
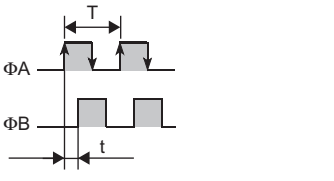
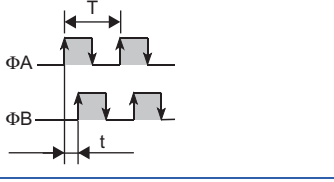
Pulse input mode	Waveform (in up count, duty ratio: 50%)	Minimum count pulse cycle, T, and phase difference, t (μs), at each counting speed								
		RD62D2					RD62P2, RD62P2E, RD62D2			
		8Mpps	4Mpps	2Mpps	1Mpps	500kpps	200kpps	100kpps	10kpps	
1-phase multiple of 1		—	—	T = 0.5	T = 1	T = 2	T = 5	T = 10	T = 100	
1-phase multiple of 2		—	T = 0.5	T = 1	T = 2	T = 4	T = 10	T = 20	T = 200	
CW/CCW		—	—	T = 0.5	T = 1	T = 2	T = 5	T = 10	T = 100	
2-phase multiple of 1		—	—	T = 0.5 t = 0.125	T = 1 t = 0.25	T = 2 t = 0.5	T = 5 t = 1.25	T = 10 t = 2.5	T = 100 t = 25	
2-phase multiple of 2		—	T = 0.5 t = 0.125	T = 1 t = 0.25	T = 2 t = 0.5	T = 4 t = 1	T = 10 t = 2.5	T = 20 t = 5	T = 200 t = 50	
2-phase multiple of 4		T = 0.5 t = 0.125	T = 1 t = 0.25	T = 2 t = 0.5	T = 4 t = 1	T = 8 t = 2	T = 20 t = 5	T = 40 t = 10	T = 400 t = 100	

# Relation between the input waveform and the phase difference of A phase pulse and B phase pulse

In 2-phase input, inputting pulses of which the phase difference is small between the A phase pulse and B phase pulse can cause an incorrect count.

The following figure shows the waveform of a pulse to be inputted to the high-speed counter module, and phase differences between the A phase pulse and B phase pulse in 2-phase input.

(The following, shown as the case of differential input, is also the same as the case of DC input.)

## Input waveform of the high-speed counter module

An input pulse waveform is subject to the following condition (duty ratio 50%):

$$T (=t_H+t_L) \geq 0.5\mu\text{s}$$
$$t_H, t_L \geq 0.25\mu\text{s} (=0.5 \times T)$$

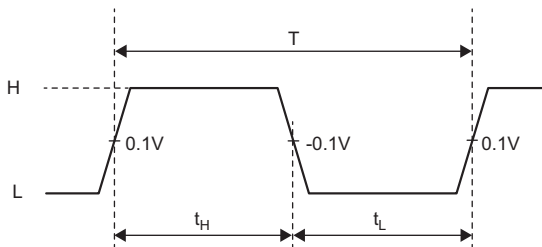

T: Minimum count pulse cycle

t: Phase difference

H: Differential voltage H level

L: Differential voltage L level

## Phase difference in 2-phase input

An input pulse waveform in 2-phase input is subject to both the above condition and the following limit on the phase differences of A phase pulse and B phase pulse:

Count	Input pulse waveform
Up count	<p><math>t_1, t_2, t_3, t_4 \geq 0.125\mu\text{s} (=0.25 \times T)</math></p>
Down count	<p><math>t_1, t_2, t_3, t_4 \geq 0.125\mu\text{s} (=0.25 \times T)</math></p>

T: Minimum count pulse cycle

t: Phase difference

H: Differential voltage H level

L: Differential voltage L level



Although the given relations in this section are based on the condition that the counting speed is maximum in each pulse input method, the relations are the same even in the condition that the counting speed is less than the maximum.

# 3 FUNCTION LIST

This section describes each counter operation mode and its corresponding functions of the high-speed counter module. For further details on the functions, refer to the following.

📖 MELSEC iQ-R High-Speed Counter Module User's Manual (Application)

## Counter operation mode

Available functions in the high-speed counter module differ depending on the counter operation mode used. Set the counter operation mode in the parameter settings. For details on the setting method, refer to the following.

📖 MELSEC iQ-R High-Speed Counter Module User's Manual (Application)

### ■Pulse count mode

This mode allows any desired count operation that combines each function and setting.

### ■Pulse measurement mode

This mode measures the following times of pulses that are input to the function start input terminal:

- ON width
- OFF width
- From the rising edge of a pulse to the rising edge of the next pulse
- From the falling edge of a pulse to the falling edge of the next pulse

### ■PWM output mode

This mode outputs a PWM waveform of up to 200kHz and down to 100ns ON width (0.1μs) from the PWM output point No.1 terminal (EQU1) and PWM output point No.2 terminal (EQU2).



## Function list

Counter operation mode	Function	Description
Pulse count mode <sup>*1</sup>	Linear counter function	Counts pulses in the range of -2147483648 (lower limit value) to 2147483647 (upper limit value). If a count exceeds the range, the overflow is detected.
	Ring counter function	Counts pulses repeatedly in the range of CH1 Ring counter lower limit value setting (Un\G20 to Un\G21) to CH1 Ring counter upper limit value setting (Un\G22 to Un\G23), which are set arbitrarily.
	Coincidence output function	Compares the present count value with the preset count value, and outputs a signal when they match.
	Coincidence detection interrupt function	Outputs an interrupt request to the CPU module and starts an interrupt program when the present counter value matches with the preset count value.
	Preset function <sup>*2</sup>	Overwrites the present counter value with an arbitrary numerical value. This function is performed with a program or an external control signal (preset input).
	Counter function selection <sup>*2</sup>	Count disable function
Latch counter function		Latches the present counter value at the signal input of Counter function selection start command.
Sampling counter function		Counts input pulses for a specified sampling time and stores the count value into the buffer memory area.
Cycle pulse counter function		Stores the current value, previous value, and difference value of the counter into the buffer memory area at every specified cycle time.
Pulse measurement mode	Pulse measurement function	Measures the following times of pulses that are input to the function start input terminal: <ul style="list-style-type: none"> <li>• ON width</li> <li>• OFF width</li> <li>• From the rising edge of a pulse to the rising edge of the next pulse</li> <li>• From the falling edge of a pulse to the falling edge of the next pulse</li> </ul>
PWM output mode	PWM output function	Outputs a PWM waveform of up to 200kHz and down to 100ns ON width (0.1μs) from the PWM output point No.1 terminal (EQU1) and PWM output point No.2 terminal (EQU2). The cycle setting or ON width setting can be changed during the PWM output operation.
—	Inter-module synchronization function	Latches the present value and measured pulse value using the synchronization signals and executes the inter-module synchronization. For details on the inter-module synchronization function, refer to the following. <ul style="list-style-type: none"> <li>📖 MELSEC iQ-R Inter-Module Synchronization Function Reference Manual</li> </ul>
—	Online module change	Allows module replacement without stopping the system. For the procedure of the online module change, refer to the following. <ul style="list-style-type: none"> <li>📖 MELSEC iQ-R Online Module Change Manual</li> </ul>

\*1 Each function in the pulse count mode can be used in combination. However, the linear counter function and ring counter function cannot be used in combination. Additionally, for the counter function selection, only one of the four functions can be selected for use.

\*2 The preset function and each function of the counter function selection can be executed by an external input as well as a program. To use the preset function, apply a voltage to the preset input terminal. To use any function of the counter function selection, apply a voltage to the function start input terminal.

# 4 PROCEDURES BEFORE OPERATION

---

This chapter describes the procedures before operation.

## 1. Mounting a module

Mount the high-speed counter module in any desired configuration.

## 2. Wiring

Perform wiring of external devices to the high-speed counter module.

 Page 26 Wiring

## 3. Adding a module

Add the high-speed counter module to a module configuration by using the engineering tool. For details, refer to the following.

 MELSEC iQ-R High-Speed Counter Module User's Manual (Application)

## 4. Parameter settings

Perform the module initial setting, module label setting, and auto refresh setting by using the engineering tool. For details, refer to the following.

 MELSEC iQ-R High-Speed Counter Module User's Manual (Application)

## 5. Programming

Create a program.

 Page 42 OPERATION EXAMPLES



# 5 INSTALLATION AND WIRING

This chapter describes the installation and wiring of the high-speed counter module.

## 5.1 Wiring

This section describes the method of wiring an encoder and a controller to the high-speed counter module.

### Wiring precautions

To obtain the maximum performance from the functions of the high-speed counter module and improve the system reliability, an external wiring with high durability against noise is required. Here are some precautions when wiring a encoder or a controller.

#### Wiring

- Different terminals are prepared depending on the voltage of the signal to be input. Connecting to a terminal with a different voltage may cause malfunction of the module or failure of the connected devices.
- In 1-phase input, always connect a pulse input cable on the A-phase side.
- To prevent burnout or damage of the external devices and module in the event of a load short circuit, install a fuse for each one external terminal in the output circuit.
- The following table lists the operation checked fuses:

Fuse model name	Rated current	Contact
312.750	0.75A	Littelfuse, Inc.
216.800	0.8A	

#### Connectors for external devices

- Connectors for external devices must be soldered or crimped properly. A poor soldering or crimping may result in malfunction.
- Securely connect the connectors for external devices to the connectors of the high-speed counter module, and securely tighten the two screws.
- When removing a cable from the high-speed counter module, do not pull the cable by the cable part. Remove a cable supporting the connector part of the cable by hand. Pulling the cable being connected to the high-speed counter module can cause malfunction. In addition, a damage of the high-speed counter module or cables can result.

## Measures against noise

- The high-speed counter module may count pulses incorrectly if pulse-like noise is input.
- For the input of high-speed pulses, take the following measures against noise:

Measure 1: Be sure to use the shielded twisted pair cables.

Measure 2: Keep the shielded twisted pair cable at a distance of 150mm or more away from power lines and I/O lines containing much noise, with the cable not being close to them. The wiring distance also should be as short as possible.

Measure 3: Ground the shielded cable on the encoder side (relay box). Individually ground the FG and LG terminals of the programmable controller with a ground resistance of 100 ohms or less.

- The following figure shows an example of the noise reduction measure:

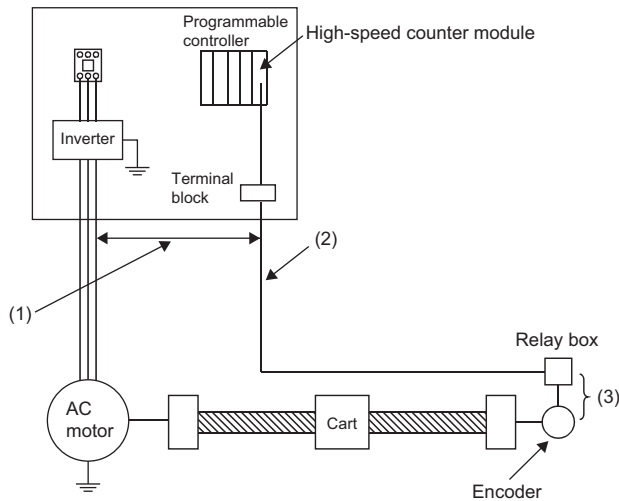

- (1) Provide a distance of 150mm or more away from I/O cables of the high voltage device such as a relay and inverter, regardless of whether inside or outside the panel.
- (2) For metal plumbing, prevent a solenoid valve or inductive load from coexisting in the pipes. Where the separate distance from a high voltage line cannot be provided sufficiently because of duct wiring and others, use the shield wire such as CVVS for the high voltage line.
- (3) The distance between the encoder and the relay box should be as short as possible. Check that the voltages both in operation and at rest of the encoder fall within the range of the rated voltage by using a measuring instrument such as a tester for the terminal block in the relay box because a long distance from the high-speed counter module to the encoder can cause a voltage drop. If the voltage drop is high, take measures such as replacing the wire to one with a larger wire size or using an encoder designed for 24VDC with a lower current consumption.

- Ground the shielded twisted pair cable on the encoder side (relay box). The following figure shows the wiring example:

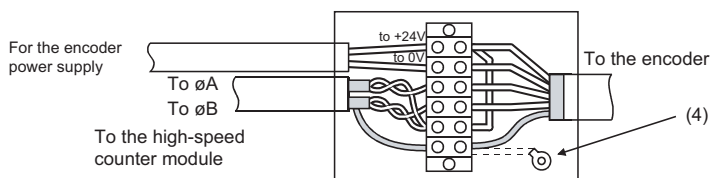

- (4) Between the encoder and the shielded twisted pair cable, connect their shield wire together in the relay box. If the shield wire of the encoder to be used is not grounded in the encoder, ground it in the relay box as the dotted line shows.

# Connectors for external devices

## Precautions

- Tighten the connector screws within the specified torque range.

Screw	Tightening torque range
Connector screw (M2.6)	0.20 to 0.29N·m

- Use copper wire with a temperature rating of 75°C or higher for the connector.
- Use UL listed connectors if necessary for UL compliance.

## Applicable connectors

Connectors for external devices to be used for the high-speed counter module are sold separately.

The following tables list the applicable connectors, and the reference product of a crimping tool.

### ■40-pin connectors

Type	Model	Applicable wire size
Soldering type connector (straight type)	A6CON1*1	0.088 to 0.3mm <sup>2</sup> (28 to 22 AWG) (stranded wire)
Crimping type connector (straight type)	A6CON2	0.088 to 0.24mm <sup>2</sup> (28 to 24 AWG) (stranded wire)
Soldering type connector (dual purpose (straight/oblique) type)	A6CON4*1	0.088 to 0.3mm <sup>2</sup> (28 to 22 AWG) (stranded wire)

- \*1 Use wire with a sheath outside diameter of 1.3mm or less when the 40 pins are used.  
Select appropriate cables according to the current value used.



The A6CON3 (IDC type connector (straight type)) cannot be used.

### ■40-pin connector crimping tool

Type	Model	Contact
Crimping tool	FCN-363T-T005/H	FUJITSU COMPONENT LIMITED

For how to wire the connector and how to use the crimping tool, contact the manufacturer.

## Wiring methods, and installation and removal procedures for the connectors

For the wiring methods, and installation and removal procedures, refer to the following.

MELSEC iQ-R Module Configuration Manual

## Interface with external devices

The following figure and table show the high-speed counter module interface for connecting external devices.

### Signal layout and pin numbers of the connector for external devices

The following figure shows the signal layout and pin numbers of the connector for external devices

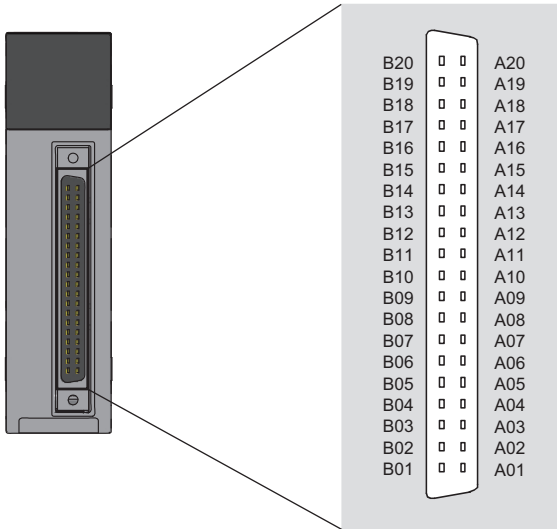

## RD62P2 (DC input sink output type)

I/O classification	Internal circuit	Pin number *1		Signal name	Operation	Input voltage (guaranteed value)	Operating current (guaranteed value)
		CH1	CH2				
Input		A20	A13	Phase A pulse input 24V	On	21.6 to 26.4V	2 to 5mA
		B20	B13		Phase A pulse input 12V	Off	5V or less
		A19	A12	Phase A pulse input 5V		On	4.5 to 5.5V
		B19	B12		ABCOM	Off	2V or less
		A18	A11	Phase B pulse input 24V		On	21.6 to 26.4V
		B18	B11		Phase B pulse input 12V	Off	5V or less
		A17	A10	Phase B pulse input 5V		On	4.5 to 5.5V
		B17	B10		Preset input 24V	Off	4V or less
		A16	A09	Preset input 12V		On	10.8 to 13.2V
		B16	B09		Preset input 5V	Off	2.5V or less
	A15	A08	CTRLCOM	On		4.5 to 5.5V	2 to 5mA
	B15	B08		Function start input 24V	Off	1.6V or less	1mA or less
	A14	A07	Function start input 12V		On	10.8 to 13.2V	2 to 5mA
	B14	B07		Function start input 5V	Off	2.5V or less	1mA or less
	—	—	—		On	4.5 to 5.5V	2 to 5mA
	—	—	—	Off	1.6V or less	1mA or less	
	Output		A06	A05	EQU1 (coincidence output point No.1) PWM1 (PWM output point No.1)	<ul style="list-style-type: none"> <li>• Operating voltage: 10.2 to 30V</li> <li>• Maximum load current: 0.5A/point, 2A/common*2</li> <li>• Maximum voltage drop at on: 1.5V</li> <li>• Response time</li> <li>Off to on: 1μs or less</li> <li>On to off: 1μs or less (rated load, resistive load)</li> </ul>	
			B06	B05			
			B02, B01	12/24V	<ul style="list-style-type: none"> <li>• Input voltage: 10.2 to 30V</li> <li>• Current consumption: 43mA (TYP., 24VDC and all points on/common)</li> <li>• Common to all channels</li> </ul>		
			A02, A01	0V			

\*1 The pins A03, A04, B03, and B04 are not assigned.

\*2 Under the range of 0 to 55°C, derating (ON ratio) of the coincidence output ensures 100% ON ratio.



## RD62P2E (DC input source output type)

I/O classification	Internal circuit	Pin number *1		Signal name	Operation	Input voltage (guaranteed value)	Operating current (guaranteed value)		
		CH1	CH2						
Input		A20	A13	Phase A pulse input 24V	On	21.6 to 26.4V	2 to 5mA		
					Off	5V or less	0.1mA or less		
		B20	B13	Phase A pulse input 12V	On	10.8 to 13.2V	2 to 5mA		
					Off	4V or less	0.1mA or less		
		A19	A12	Phase A pulse input 5V	On	4.5 to 5.5V	2 to 5mA		
					Off	2V or less	0.1mA or less		
		B19	B12	ABCOM	—	—	—		
		A18	A11	Phase B pulse input 24V	On	21.6 to 26.4V	2 to 5mA		
					Off	5V or less	0.1mA or less		
		B18	B11	Phase B pulse input 12V	On	10.8 to 13.2V	2 to 5mA		
					Off	4V or less	0.1mA or less		
		A17	A10	Phase B pulse input 5V	On	4.5 to 5.5V	2 to 5mA		
					Off	2V or less	0.1mA or less		
				B17	B10	Preset input 24V	On	21.6 to 26.4V	7 to 10mA
							Off	4V or less	1mA or less
				A16	A09	Preset input 12V	On	10.8 to 13.2V	7 to 10mA
							Off	2.5V or less	1mA or less
				B16	B09	Preset input 5V	On	4.5 to 5.5V	7 to 10mA
				Off	1.6V or less		1mA or less		
		A15	A08	CTRLCOM	Response time	Off to on 20μs or less	On to off 100μs or less		
		B15	B08	Function start input 24V	On	21.6 to 26.4V	7 to 10mA		
					Off	4V or less	1mA or less		
		A14	A07	Function start input 12V	On	10.8 to 13.2V	7 to 10mA		
					Off	2.5V or less	1mA or less		
		B14	B07	Function start input 5V	On	4.5 to 5.5V	7 to 10mA		
					Off	1.6V or less	1mA or less		
		—	—	—	Response time	Off to on 20μs or less	On to off 100μs or less		
Output		A06	A05	EQU1 (coincidence output point No.1) PWM1 (PWM output point No.1)	<ul style="list-style-type: none"> <li>• Operating voltage: 10.2 to 30V</li> <li>• Maximum load current: 0.1A/point, 0.4A/common*2</li> <li>• Maximum voltage drop at on: 1.5V</li> <li>• Response time</li> </ul> Off to on: 1μs or less On to off: 1μs or less (rated load, resistive load)				
		B06	B05				EQU2 (coincidence output point No.2) PWM2 (PWM output point No.2)		
		B02	B01	12/24V					
		B02, B01						<ul style="list-style-type: none"> <li>• Input voltage: 10.2 to 30V</li> <li>• Current consumption: 43mA (TYP., 24VDC and all points on/common)</li> <li>• Common to all channels</li> </ul>	

\*1 The pins A01, A02, A03, A04, B03, and B04 are not assigned.

\*2 Under the range of 0 to 55°C, derating (ON ratio) of the coincidence output ensures 100% ON ratio.

## RD62D2 (differential input sink output type)

I/O classification	Internal circuit	Pin number *1		Signal name	Operation	Input voltage (guaranteed value)	Operating current (guaranteed value)
		CH1	CH2				
Input		A20	A14	Phase A pulse input	EIA Standard RS-422-A Line receiver (AM26C32 (manufactured by Texas Instruments Japan Limited.) or equivalent) The line receiver specifications are as follows: • VIT + Differential input on voltage (H level threshold voltage) 0.2V • VIT - Differential input off voltage (L level threshold voltage) - 0.2V • Vhys hysteresis voltage (VIT + - VIT -) 60mV (A current type line driver cannot be used.)		
		B20	B14	Phase A pulse input			
		A19	A13	Phase B pulse input			
		B19	B13	Phase B pulse input			
		A18	A12	Preset input 24V	On	21.6 to 26.4V	7 to 10mA
					Off	4V or less	1mA or less
		B18	B12	Preset input 12V	On	10.8 to 13.2V	7 to 10mA
					Off	2.5V or less	1mA or less
		A17	A11	Preset input 5V	On	2.5 to 5.5V	7 to 10mA
					Off	1.6V or less	1mA or less
		A16	A10	Function start input 24V	On	21.6 to 26.4V	7 to 10mA
					Off	4V or less	1mA or less
B16		B10	Function start input 12V	On	10.8 to 13.2V	7 to 10mA	
				Off	2.5V or less	1mA or less	
A15		A09	Function start input 5V	On	2.5 to 5.5V	7 to 10mA	
				Off	1.6V or less	1mA or less	
	A06	A05	EQU1 (coincidence output point No.1) PWM1 (PWM output point No.1)	• Operating voltage: 10.2 to 30V • Maximum load current: 0.5A/point, 2A/common*2 • Maximum voltage drop at on: 1.5V • Response time Off to on: 1μs or less On to off: 1μs or less (rated load, resistive load)			
	B06	B05	EQU2 (coincidence output point No.2) PWM2 (PWM output point No.2)				
	B02, B01		12/24V		• Input voltage: 10.2 to 30V		
	A02, A01		0V		• Current consumption: 43mA (TYP., 24VDC and all points on/common)		
					• Common to all channels		

\*1 The pins A03, A04, A07, A08, B03, B04, B07, and B08 are not assigned.

\*2 Under the range of 0 to 55°C, derating (ON ratio) of the coincidence output ensures 100% ON ratio.

## Connectable encoders

---

The following lists the encoders that can be connected to the high-speed counter module.

### Types of the encoder that can be connected to the RD62P2 and RD62P2E

- Open collector output type encoder
- Voltage output type encoder

(Check that the encoder output voltage and output current meet the specifications of the RD62P2 and RD62P2E.)

### Type of the encoder that can be connected to the RD62D2

- Line driver output type encoder

(Check that the encoder output voltage meets the specifications of the RD62D2.)

## 5.2 Examples of Wiring Between the High-Speed Counter Module and an Encoder

### Example of wiring with an open collector output type encoder (24VDC)

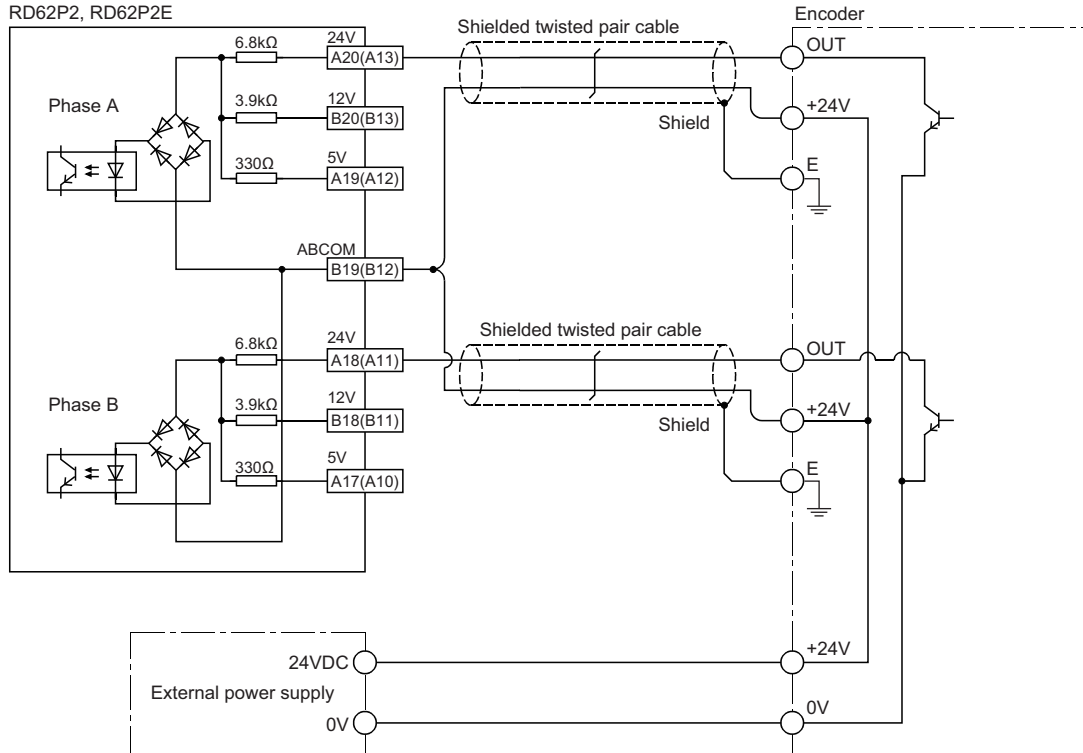

Alphanumeric characters in the parentheses ( ) indicate the pin number of the channel 2.

#### Point

For the wiring between an encoder and the RD62P2 or RD62P2E, separate the power supply cables and the signal cables. The following figure shows examples:

- Wiring example

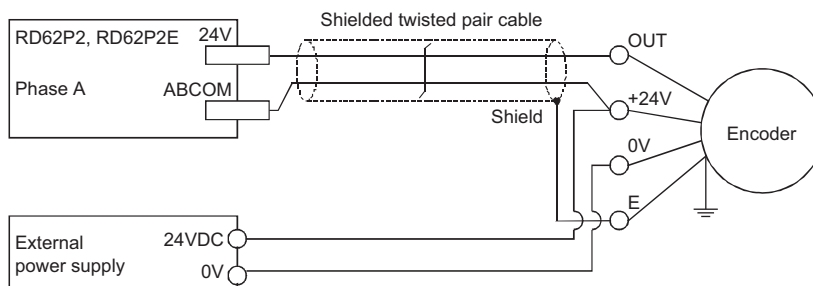

- Wiring example to be avoided

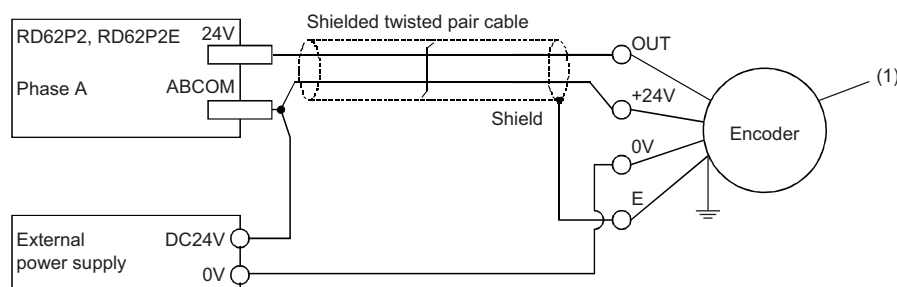

(1): Since a current flows through the shielded twisted pair cable only in one direction, the canceling effects are lost, which causes the line to be more affected by electromagnetic induction.

## Example of wiring with a voltage output type encoder (5VDC)

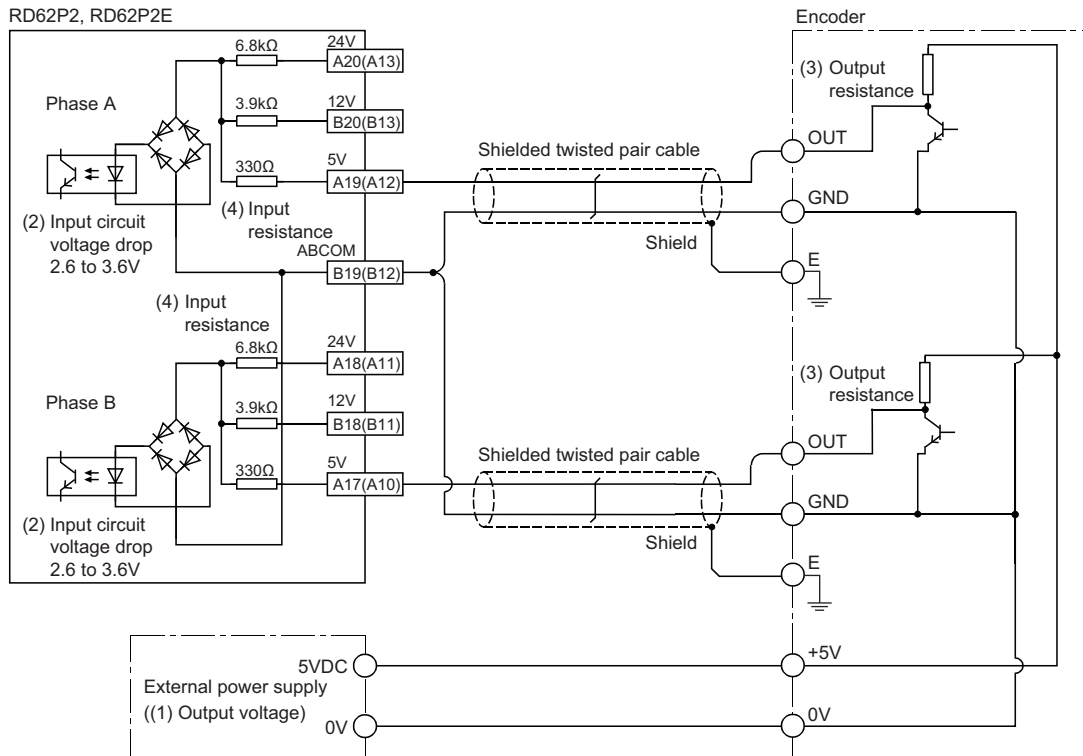

Alphanumeric characters in the parentheses ( ) indicate the pin number of the channel 2.

### Precautions

For the wiring with a voltage output type pulse generator, add the (3) Output resistance to the calculation formula below and check that the input pulse current meets the specifications of input current. In addition, check the operation using an actual module and device.

- Input pulse current =  $((1) - (2)) \div ((3) + (4))$
- (1) Output voltage
- (2) Input circuit voltage drop
- (3) Output resistance
- (4) Input resistance (Use a terminal that meets the specifications of input current as an input resistance.)

#### Ex.

The calculation examples below are for obtaining the value of input pulse current to flow when the module is connected to a 24VDC output pulse generator with the output resistance of 1kΩ. Assume that an input terminal of 24VDC is used as an input resistance.

- Input pulse current (Min) =  $(24V - 3.6V) \div (1k\Omega + 6.8k\Omega) = 2.62mA$
- Input pulse current (Max) =  $(24V - 2.6V) \div (1k\Omega + 6.8k\Omega) = 2.74mA$

The input pulse current is within the range of 2.62mA (Min) to 2.74mA (Max), which meets the input specifications (ON current of input: 2 to 5mA).

## Example of wiring with a line driver (equivalent to AM26LS31) encoder

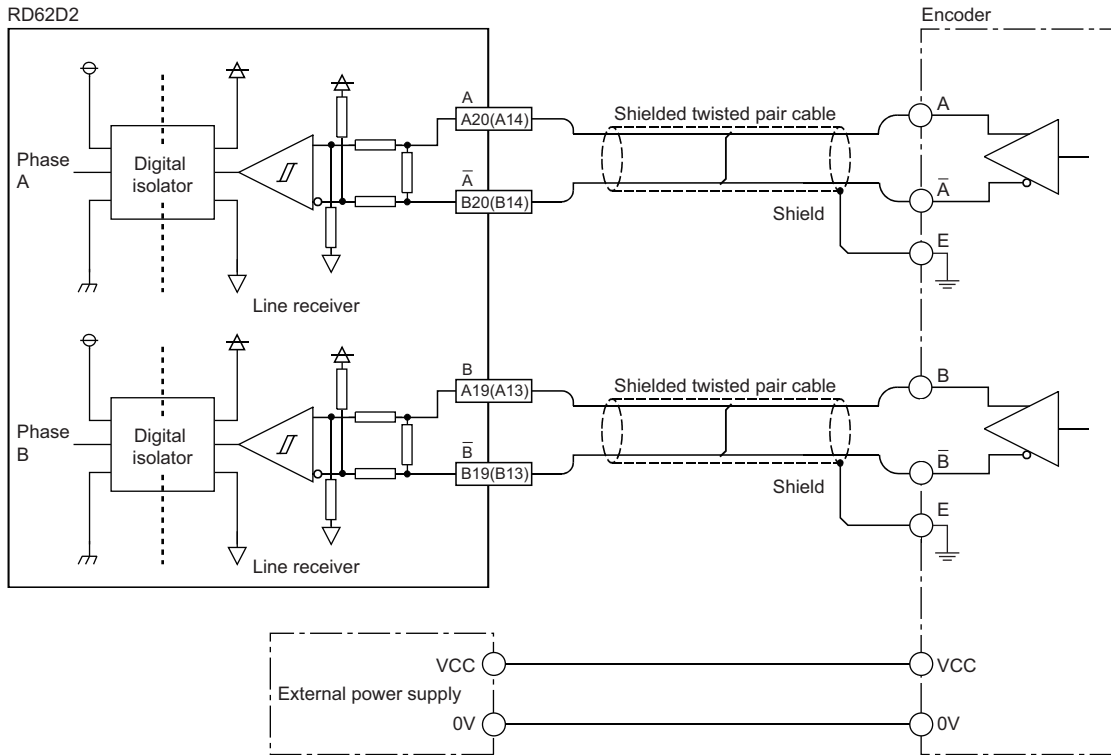

Alphanumeric characters in the parentheses ( ) indicate the pin number of the channel 2.

# 5.3 Examples of Wiring Between a Controller and External Input Terminals

## When the controller (sync load type) has a voltage of 12VDC

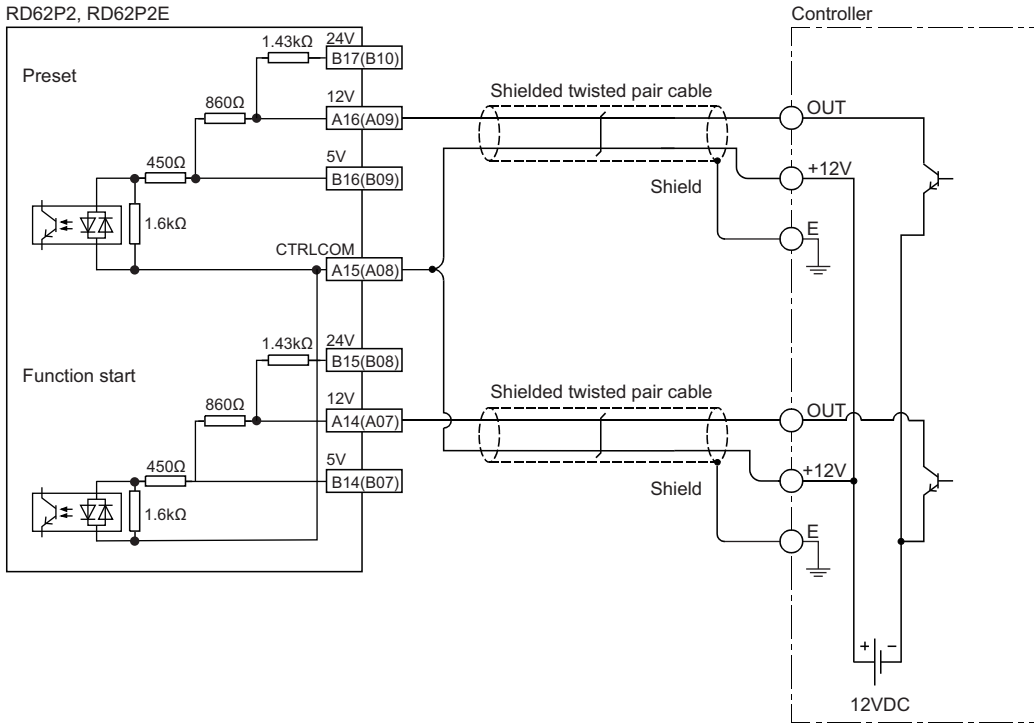

Alphanumeric characters in the parentheses ( ) indicate the pin number of the channel 2.

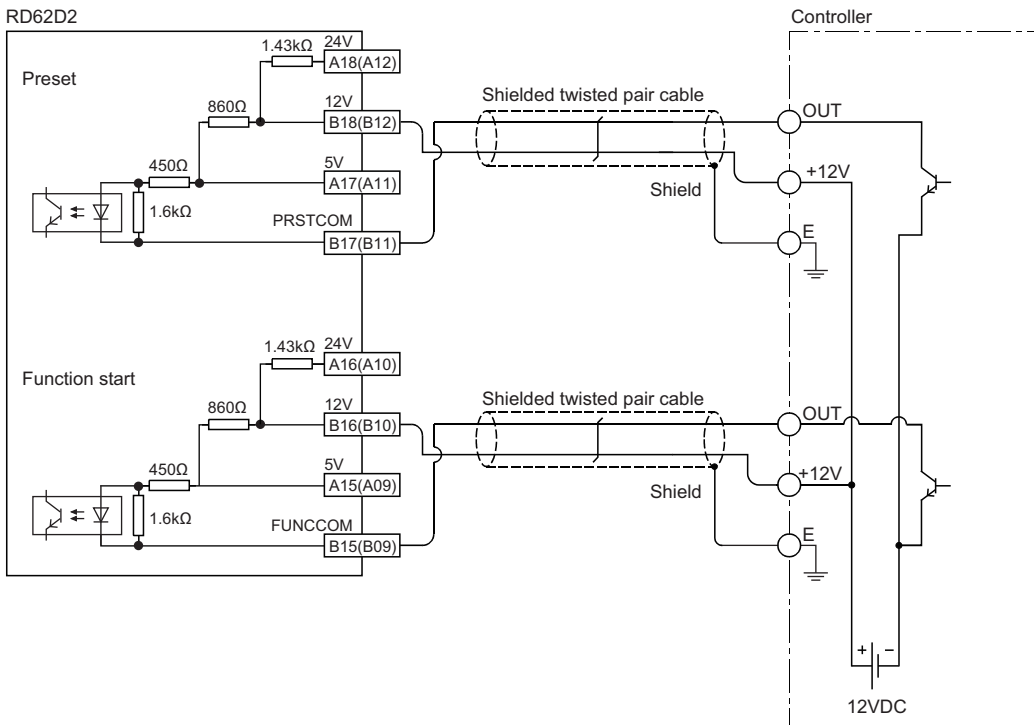

Alphanumeric characters in the parentheses ( ) indicate the pin number of the channel 2.

## When the controller (source load type) has a voltage of 5VDC

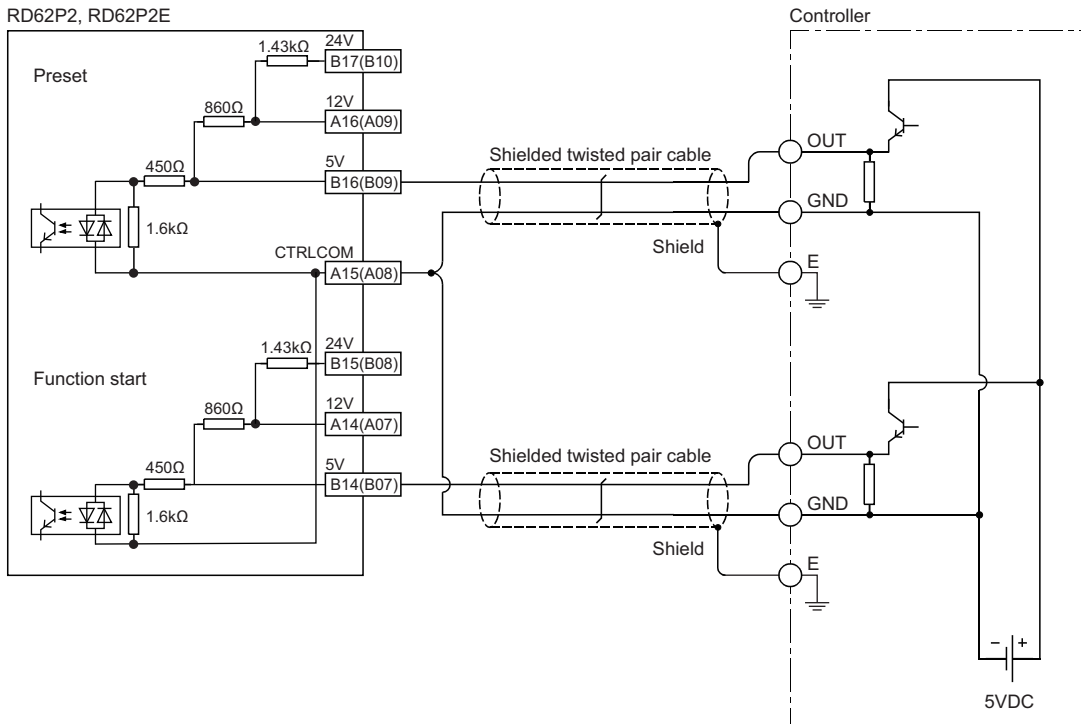

Alphanumeric characters in the parentheses ( ) indicate the pin number of the channel 2.

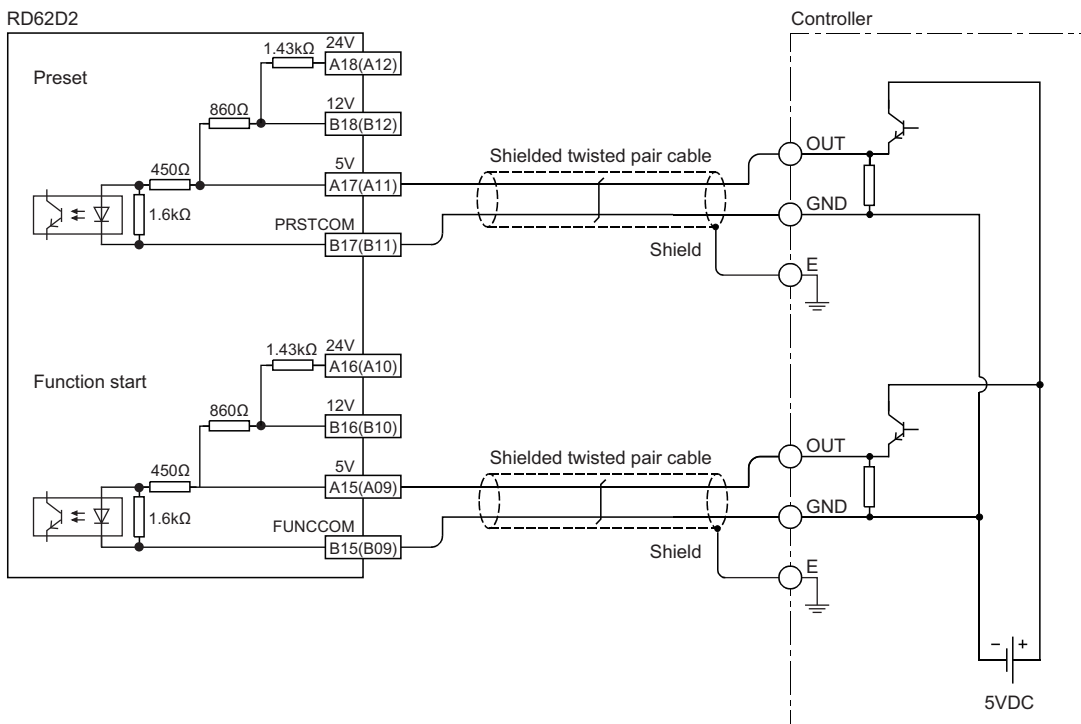

Alphanumeric characters in the parentheses ( ) indicate the pin number of the channel 2.



## When the controller is a line driver type

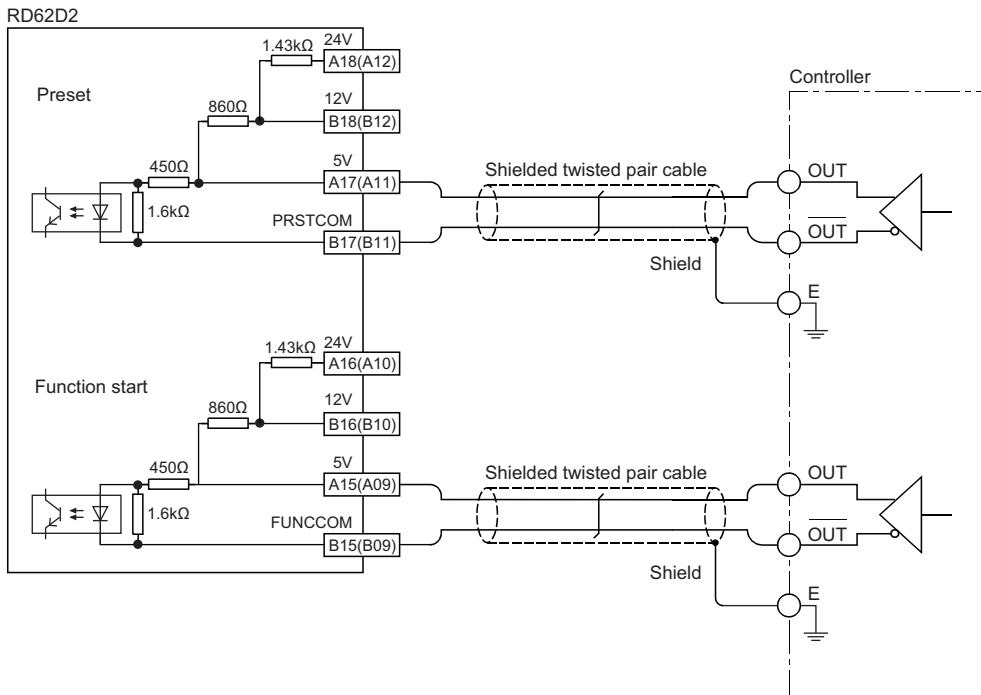

Alphanumeric characters in the parentheses ( ) indicate the pin number of the channel 2.

# 5.4 Examples of Wiring with External Output Terminals

When using an EQU terminal (coincidence output), an external power supply of 10.2 to 30VDC is required to drive the internal photocoupler.

## For the sink output type (RD62P2 and RD62D2)

RD62P2, RD62D2

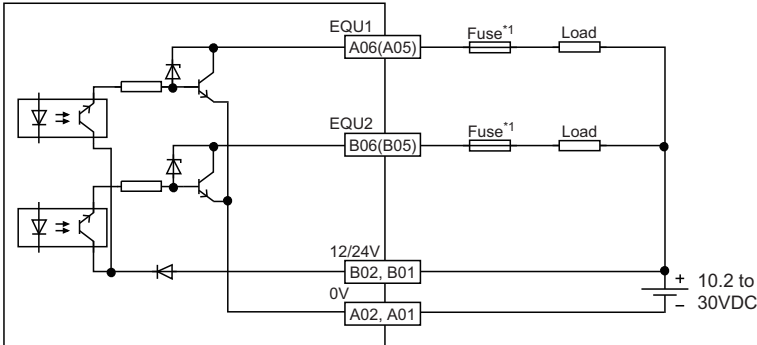

Alphanumeric characters in the parentheses ( ) indicate the pin number of the channel 2.

\*1 To prevent burnout or damage of the external devices and module in the event of a load short circuit, install a fuse for each one external terminal in the output circuit. For the operation checked fuses, refer to the following.

☞ Page 26 Wiring

## For the source output type (RD62P2E)

RD62P2E

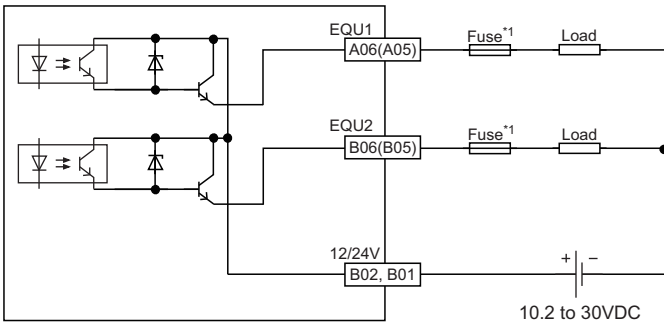

Alphanumeric characters in the parentheses ( ) indicate the pin number of the channel 2.

\*1 To prevent burnout or damage of the external devices and module in the event of a load short circuit, install a fuse for each one external terminal in the output circuit. For the operation checked fuses, refer to the following.

☞ Page 26 Wiring



# 6 OPERATION EXAMPLES

---

This chapter describes the programming procedure and the basic programs of the high-speed counter module. When applying the program examples provided in this manual to an actual system, properly verify the applicability and reliability of the control on the system.

## 6.1 Programming Procedure

---

Take the following steps to create a program for the count operation:

1. Start creating the program.
2. Parameter settings  
☞ Page 44 Parameter settings
3. Program example of the mode used  
☞ Page 45 Program example for pulse count mode
4. Finish creating the program.

## 6.2 Program Examples

This section shows the system configuration and program examples based on conditions.

### System configuration

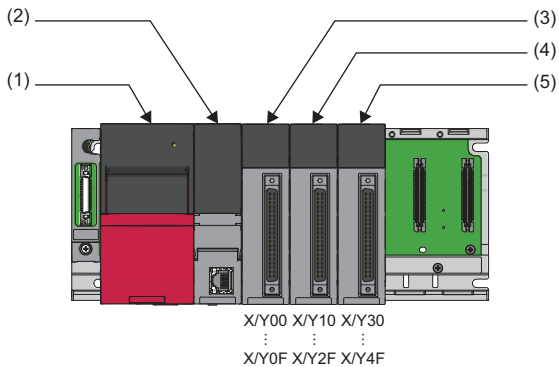

- (1) Power supply module (R61P)
- (2) CPU module (R04CPU)
- (3) High-speed counter module (RD62P2)
- (4) Input module (RX41C4)
- (5) Output module (RY41NT2P)

### Conditions in the program

This program is meant to make the high-speed counter module perform the count operation on the following conditions:

Description	Setting value
Channel	CH1
Pulse input mode	2-phase multiple of 1
Counting speed setting	200kpps
Counter type	Selectable by a user
Preset value	2500
Coincidence output point No.1	1000
Coincidence output point No.2	2000
Ring counter lower limit value <sup>*1</sup>	-5000
Ring counter upper limit value <sup>*1</sup>	5000
Sampling time setting <sup>*2</sup>	10000ms
Cycle time setting <sup>*3</sup>	5000ms
PWM output cycle time setting <sup>*4</sup>	150μs
PWM output ON time setting <sup>*4</sup>	50μs
Pulse measurement section setting <sup>*5</sup>	Rise—Rise

- \*1 Needs to be set only when using the ring counter function.
- \*2 Needs to be set only when using the sampling counter function.
- \*3 Needs to be set only when using the cycle pulse counter function.
- \*4 Needs to be set only when using PWM output mode.
- \*5 Needs to be set only when using pulse measurement mode.

## Parameter settings

Some of the initial setting needs to be set in the parameter settings of the engineering tool. For details on the parameter settings, refer to the following.

 MELSEC iQ-R High-Speed Counter Module User's Manual (Application)

Setting item	Description	Setting value
Pulse input mode	Set pulse input mode.	3: 2-phase multiple of 1
Counting speed setting	Set the counting speed.	2: 200kpps
Counter type	Set the counter type.	Selectable by a user
Counter operation mode	Set pulse input mode.	Set the mode to be used.
Ring counter lower limit value	Set these values only when using the ring counter function.	-5000
Ring counter upper limit value		5000
Pulse measurement section setting	Set the pulse measurement section.	2: Rise—Rise

## Label settings

GX Works3 provides functions that support the creation of a program.

The following table lists the global labels used for the program examples in this section.

For details on the global labels, refer to the following.

 MELSEC iQ-R Programming Manual (Program Design)

Mode	Label name																																																																																																																																																																
Program example for pulse count mode	<table border="1"> <thead> <tr> <th>Label Name</th> <th>Data Type</th> <th>Class</th> <th>Assign (Device/Label)</th> </tr> </thead> <tbody> <tr><td>ERR</td><td>Word [Unsigned]/Bit String [16-bit]</td><td>VAR_GLOBAL</td><td>D0</td></tr> <tr><td>LatchCount</td><td>Double Word [Signed]</td><td>VAR_GLOBAL</td><td>D200</td></tr> <tr><td>SamplingCount</td><td>Double Word [Signed]</td><td>VAR_GLOBAL</td><td>D300</td></tr> <tr><td>PreviousValue</td><td>Double Word [Signed]</td><td>VAR_GLOBAL</td><td>D400</td></tr> <tr><td>PresentValue</td><td>Double Word [Signed]</td><td>VAR_GLOBAL</td><td>D402</td></tr> <tr><td>ENOut0</td><td>Bit</td><td>VAR_GLOBAL</td><td>M1</td></tr> <tr><td>OK0</td><td>Bit</td><td>VAR_GLOBAL</td><td>M2</td></tr> <tr><td>ERRstate0</td><td>Bit</td><td>VAR_GLOBAL</td><td>M3</td></tr> <tr><td>ENOut1</td><td>Bit</td><td>VAR_GLOBAL</td><td>M11</td></tr> <tr><td>OK1</td><td>Bit</td><td>VAR_GLOBAL</td><td>M12</td></tr> <tr><td>ERRstate1</td><td>Bit</td><td>VAR_GLOBAL</td><td>M13</td></tr> <tr><td>ENOut2</td><td>Bit</td><td>VAR_GLOBAL</td><td>M21</td></tr> <tr><td>OK2</td><td>Bit</td><td>VAR_GLOBAL</td><td>M22</td></tr> <tr><td>ERRstate2</td><td>Bit</td><td>VAR_GLOBAL</td><td>M23</td></tr> <tr><td>ENOut3</td><td>Bit</td><td>VAR_GLOBAL</td><td>M31</td></tr> <tr><td>OK3</td><td>Bit</td><td>VAR_GLOBAL</td><td>M32</td></tr> <tr><td>ERRstate3</td><td>Bit</td><td>VAR_GLOBAL</td><td>M33</td></tr> <tr><td>ENOut4</td><td>Bit</td><td>VAR_GLOBAL</td><td>M41</td></tr> <tr><td>OK4</td><td>Bit</td><td>VAR_GLOBAL</td><td>M42</td></tr> <tr><td>ERRstate4</td><td>Bit</td><td>VAR_GLOBAL</td><td>M43</td></tr> <tr><td>ENOut5</td><td>Bit</td><td>VAR_GLOBAL</td><td>M51</td></tr> <tr><td>OK5</td><td>Bit</td><td>VAR_GLOBAL</td><td>M52</td></tr> <tr><td>ERRstate5</td><td>Bit</td><td>VAR_GLOBAL</td><td>M53</td></tr> <tr><td>ENOut6</td><td>Bit</td><td>VAR_GLOBAL</td><td>M61</td></tr> <tr><td>OK6</td><td>Bit</td><td>VAR_GLOBAL</td><td>M62</td></tr> <tr><td>ERRstate6</td><td>Bit</td><td>VAR_GLOBAL</td><td>M63</td></tr> <tr><td>ENOut7</td><td>Bit</td><td>VAR_GLOBAL</td><td>M71</td></tr> <tr><td>OK7</td><td>Bit</td><td>VAR_GLOBAL</td><td>M72</td></tr> <tr><td>ERRstate7</td><td>Bit</td><td>VAR_GLOBAL</td><td>M73</td></tr> <tr><td>CountOperationStartSignal</td><td>Bit</td><td>VAR_GLOBAL</td><td>X10</td></tr> <tr><td>CoincidenceOutputDataSettingSignal</td><td>Bit</td><td>VAR_GLOBAL</td><td>X12</td></tr> <tr><td>PresetCommandSignal</td><td>Bit</td><td>VAR_GLOBAL</td><td>X13</td></tr> <tr><td>CoincidenceOutputEnableSignal</td><td>Bit</td><td>VAR_GLOBAL</td><td>X14</td></tr> <tr><td>CountDisableExecutionSignal</td><td>Bit</td><td>VAR_GLOBAL</td><td>X16</td></tr> <tr><td>LatchExecutionSignal</td><td>Bit</td><td>VAR_GLOBAL</td><td>X19</td></tr> <tr><td>SamplingCountStartSignal</td><td>Bit</td><td>VAR_GLOBAL</td><td>X1B</td></tr> <tr><td>PeriodicPulseCountStartSignal</td><td>Bit</td><td>VAR_GLOBAL</td><td>X1C</td></tr> <tr><td>OutEnableNo1</td><td>Bit</td><td>VAR_GLOBAL</td><td>X21</td></tr> <tr><td>OutEnableNo2</td><td>Bit</td><td>VAR_GLOBAL</td><td>X22</td></tr> </tbody> </table>	Label Name	Data Type	Class	Assign (Device/Label)	ERR	Word [Unsigned]/Bit String [16-bit]	VAR_GLOBAL	D0	LatchCount	Double Word [Signed]	VAR_GLOBAL	D200	SamplingCount	Double Word [Signed]	VAR_GLOBAL	D300	PreviousValue	Double Word [Signed]	VAR_GLOBAL	D400	PresentValue	Double Word [Signed]	VAR_GLOBAL	D402	ENOut0	Bit	VAR_GLOBAL	M1	OK0	Bit	VAR_GLOBAL	M2	ERRstate0	Bit	VAR_GLOBAL	M3	ENOut1	Bit	VAR_GLOBAL	M11	OK1	Bit	VAR_GLOBAL	M12	ERRstate1	Bit	VAR_GLOBAL	M13	ENOut2	Bit	VAR_GLOBAL	M21	OK2	Bit	VAR_GLOBAL	M22	ERRstate2	Bit	VAR_GLOBAL	M23	ENOut3	Bit	VAR_GLOBAL	M31	OK3	Bit	VAR_GLOBAL	M32	ERRstate3	Bit	VAR_GLOBAL	M33	ENOut4	Bit	VAR_GLOBAL	M41	OK4	Bit	VAR_GLOBAL	M42	ERRstate4	Bit	VAR_GLOBAL	M43	ENOut5	Bit	VAR_GLOBAL	M51	OK5	Bit	VAR_GLOBAL	M52	ERRstate5	Bit	VAR_GLOBAL	M53	ENOut6	Bit	VAR_GLOBAL	M61	OK6	Bit	VAR_GLOBAL	M62	ERRstate6	Bit	VAR_GLOBAL	M63	ENOut7	Bit	VAR_GLOBAL	M71	OK7	Bit	VAR_GLOBAL	M72	ERRstate7	Bit	VAR_GLOBAL	M73	CountOperationStartSignal	Bit	VAR_GLOBAL	X10	CoincidenceOutputDataSettingSignal	Bit	VAR_GLOBAL	X12	PresetCommandSignal	Bit	VAR_GLOBAL	X13	CoincidenceOutputEnableSignal	Bit	VAR_GLOBAL	X14	CountDisableExecutionSignal	Bit	VAR_GLOBAL	X16	LatchExecutionSignal	Bit	VAR_GLOBAL	X19	SamplingCountStartSignal	Bit	VAR_GLOBAL	X1B	PeriodicPulseCountStartSignal	Bit	VAR_GLOBAL	X1C	OutEnableNo1	Bit	VAR_GLOBAL	X21	OutEnableNo2	Bit	VAR_GLOBAL	X22
	Label Name	Data Type	Class	Assign (Device/Label)																																																																																																																																																													
	ERR	Word [Unsigned]/Bit String [16-bit]	VAR_GLOBAL	D0																																																																																																																																																													
	LatchCount	Double Word [Signed]	VAR_GLOBAL	D200																																																																																																																																																													
	SamplingCount	Double Word [Signed]	VAR_GLOBAL	D300																																																																																																																																																													
	PreviousValue	Double Word [Signed]	VAR_GLOBAL	D400																																																																																																																																																													
	PresentValue	Double Word [Signed]	VAR_GLOBAL	D402																																																																																																																																																													
	ENOut0	Bit	VAR_GLOBAL	M1																																																																																																																																																													
	OK0	Bit	VAR_GLOBAL	M2																																																																																																																																																													
	ERRstate0	Bit	VAR_GLOBAL	M3																																																																																																																																																													
	ENOut1	Bit	VAR_GLOBAL	M11																																																																																																																																																													
	OK1	Bit	VAR_GLOBAL	M12																																																																																																																																																													
	ERRstate1	Bit	VAR_GLOBAL	M13																																																																																																																																																													
	ENOut2	Bit	VAR_GLOBAL	M21																																																																																																																																																													
	OK2	Bit	VAR_GLOBAL	M22																																																																																																																																																													
	ERRstate2	Bit	VAR_GLOBAL	M23																																																																																																																																																													
	ENOut3	Bit	VAR_GLOBAL	M31																																																																																																																																																													
	OK3	Bit	VAR_GLOBAL	M32																																																																																																																																																													
	ERRstate3	Bit	VAR_GLOBAL	M33																																																																																																																																																													
	ENOut4	Bit	VAR_GLOBAL	M41																																																																																																																																																													
	OK4	Bit	VAR_GLOBAL	M42																																																																																																																																																													
	ERRstate4	Bit	VAR_GLOBAL	M43																																																																																																																																																													
	ENOut5	Bit	VAR_GLOBAL	M51																																																																																																																																																													
	OK5	Bit	VAR_GLOBAL	M52																																																																																																																																																													
	ERRstate5	Bit	VAR_GLOBAL	M53																																																																																																																																																													
	ENOut6	Bit	VAR_GLOBAL	M61																																																																																																																																																													
	OK6	Bit	VAR_GLOBAL	M62																																																																																																																																																													
ERRstate6	Bit	VAR_GLOBAL	M63																																																																																																																																																														
ENOut7	Bit	VAR_GLOBAL	M71																																																																																																																																																														
OK7	Bit	VAR_GLOBAL	M72																																																																																																																																																														
ERRstate7	Bit	VAR_GLOBAL	M73																																																																																																																																																														
CountOperationStartSignal	Bit	VAR_GLOBAL	X10																																																																																																																																																														
CoincidenceOutputDataSettingSignal	Bit	VAR_GLOBAL	X12																																																																																																																																																														
PresetCommandSignal	Bit	VAR_GLOBAL	X13																																																																																																																																																														
CoincidenceOutputEnableSignal	Bit	VAR_GLOBAL	X14																																																																																																																																																														
CountDisableExecutionSignal	Bit	VAR_GLOBAL	X16																																																																																																																																																														
LatchExecutionSignal	Bit	VAR_GLOBAL	X19																																																																																																																																																														
SamplingCountStartSignal	Bit	VAR_GLOBAL	X1B																																																																																																																																																														
PeriodicPulseCountStartSignal	Bit	VAR_GLOBAL	X1C																																																																																																																																																														
OutEnableNo1	Bit	VAR_GLOBAL	X21																																																																																																																																																														
OutEnableNo2	Bit	VAR_GLOBAL	X22																																																																																																																																																														
Program example for pulse measurement mode	<table border="1"> <thead> <tr> <th>Label Name</th> <th>Data Type</th> <th>Class</th> <th>Assign (Device/Label)</th> </tr> </thead> <tbody> <tr><td>ERR</td><td>Word [Unsigned]/Bit String [16-bit]</td><td>VAR_GLOBAL</td><td>D0</td></tr> <tr><td>Result</td><td>Double Word [Signed]</td><td>VAR_GLOBAL</td><td>D500</td></tr> <tr><td>ENout8</td><td>Bit</td><td>VAR_GLOBAL</td><td>M81</td></tr> <tr><td>OK8</td><td>Bit</td><td>VAR_GLOBAL</td><td>M82</td></tr> <tr><td>ERRstate8</td><td>Bit</td><td>VAR_GLOBAL</td><td>M83</td></tr> <tr><td>PulseUpdate</td><td>Bit</td><td>VAR_GLOBAL</td><td>M84</td></tr> <tr><td>PulseMeasureStart</td><td>Bit</td><td>VAR_GLOBAL</td><td>X1E</td></tr> </tbody> </table>	Label Name	Data Type	Class	Assign (Device/Label)	ERR	Word [Unsigned]/Bit String [16-bit]	VAR_GLOBAL	D0	Result	Double Word [Signed]	VAR_GLOBAL	D500	ENout8	Bit	VAR_GLOBAL	M81	OK8	Bit	VAR_GLOBAL	M82	ERRstate8	Bit	VAR_GLOBAL	M83	PulseUpdate	Bit	VAR_GLOBAL	M84	PulseMeasureStart	Bit	VAR_GLOBAL	X1E																																																																																																																																
	Label Name	Data Type	Class	Assign (Device/Label)																																																																																																																																																													
	ERR	Word [Unsigned]/Bit String [16-bit]	VAR_GLOBAL	D0																																																																																																																																																													
	Result	Double Word [Signed]	VAR_GLOBAL	D500																																																																																																																																																													
	ENout8	Bit	VAR_GLOBAL	M81																																																																																																																																																													
	OK8	Bit	VAR_GLOBAL	M82																																																																																																																																																													
	ERRstate8	Bit	VAR_GLOBAL	M83																																																																																																																																																													
PulseUpdate	Bit	VAR_GLOBAL	M84																																																																																																																																																														
PulseMeasureStart	Bit	VAR_GLOBAL	X1E																																																																																																																																																														

Mode	Label name																								
Program example for PWM output mode	<table border="1"> <thead> <tr> <th>Label Name</th> <th>Data Type</th> <th>Class</th> <th>Assign (Device/Label)</th> </tr> </thead> <tbody> <tr> <td>ERR</td> <td>Word [Unsigned]/Bit String [16-bit]</td> <td>VAR_GLOBAL</td> <td>D0</td> </tr> <tr> <td>ENout9</td> <td>Bit</td> <td>VAR_GLOBAL</td> <td>M91</td> </tr> <tr> <td>OK9</td> <td>Bit</td> <td>VAR_GLOBAL</td> <td>M92</td> </tr> <tr> <td>ERRStates9</td> <td>Bit</td> <td>VAR_GLOBAL</td> <td>M93</td> </tr> <tr> <td>PWMOutputStart</td> <td>Bit</td> <td>VAR_GLOBAL</td> <td>X20</td> </tr> </tbody> </table>	Label Name	Data Type	Class	Assign (Device/Label)	ERR	Word [Unsigned]/Bit String [16-bit]	VAR_GLOBAL	D0	ENout9	Bit	VAR_GLOBAL	M91	OK9	Bit	VAR_GLOBAL	M92	ERRStates9	Bit	VAR_GLOBAL	M93	PWMOutputStart	Bit	VAR_GLOBAL	X20
	Label Name	Data Type	Class	Assign (Device/Label)																					
	ERR	Word [Unsigned]/Bit String [16-bit]	VAR_GLOBAL	D0																					
	ENout9	Bit	VAR_GLOBAL	M91																					
	OK9	Bit	VAR_GLOBAL	M92																					
	ERRStates9	Bit	VAR_GLOBAL	M93																					
PWMOutputStart	Bit	VAR_GLOBAL	X20																						

## Program example for pulse count mode

This program example uses the function blocks (FBs) that appear in "Module POU".

For details on the function blocks, refer to the following.

📖 MELSEC iQ-R High-Speed Counter Module Function Block Reference

### ■ Program example for pulse count mode

- Starting the count operation

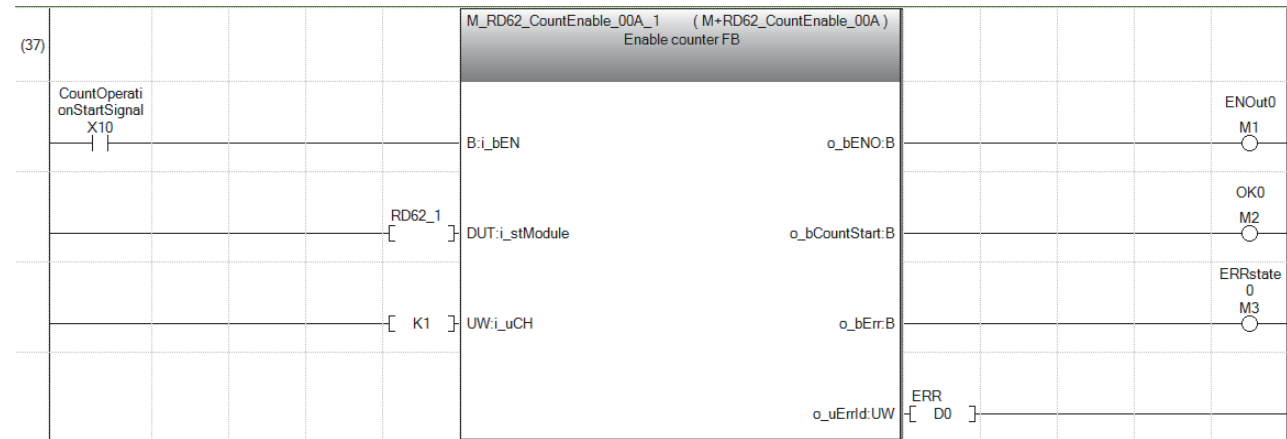

- Setting the coincidence output function

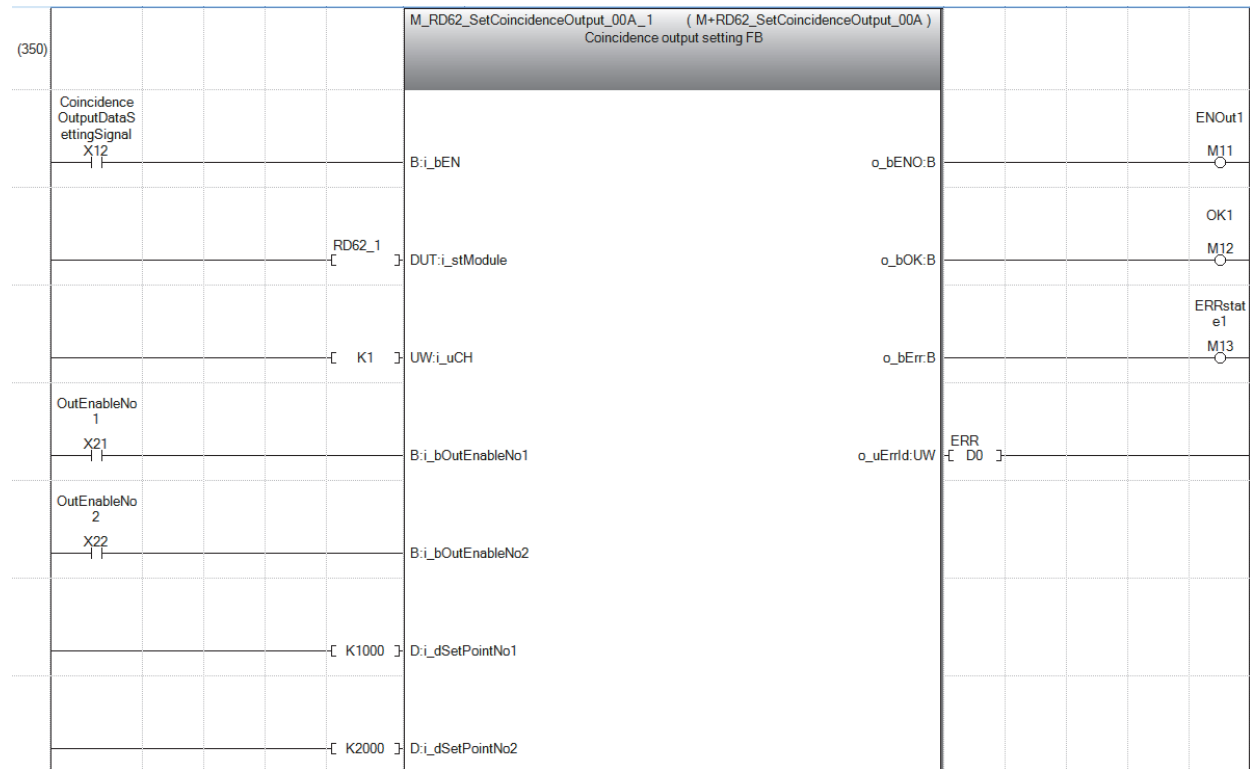

• Enabling the external coincidence output

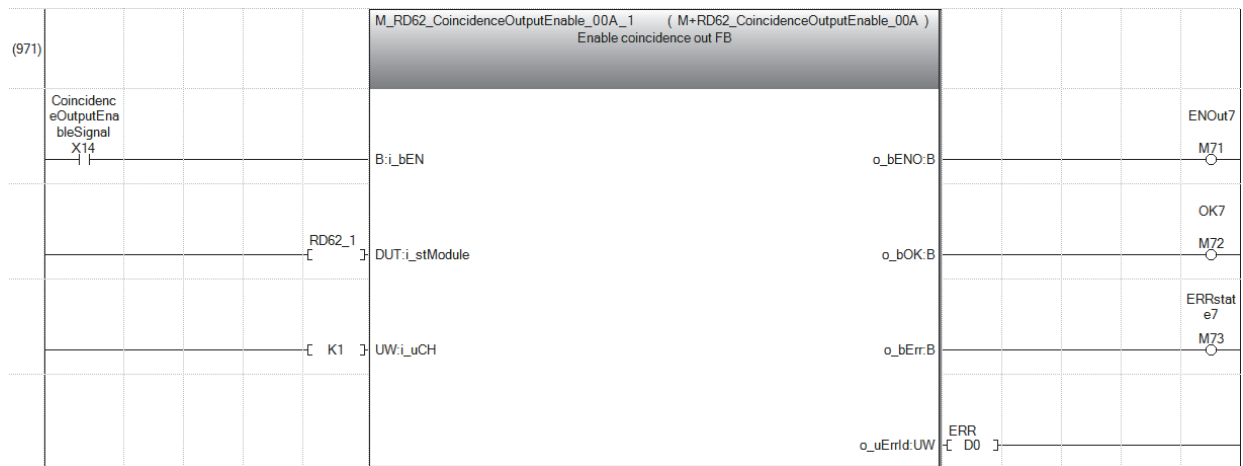

• Executing a preset

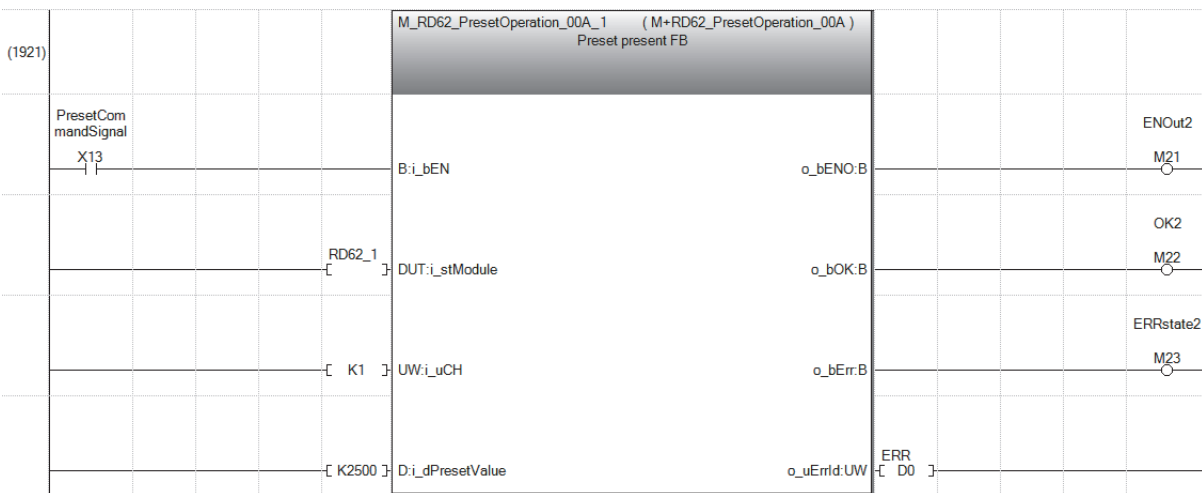

■ Program example for the counter function selection

• When using the count disable function

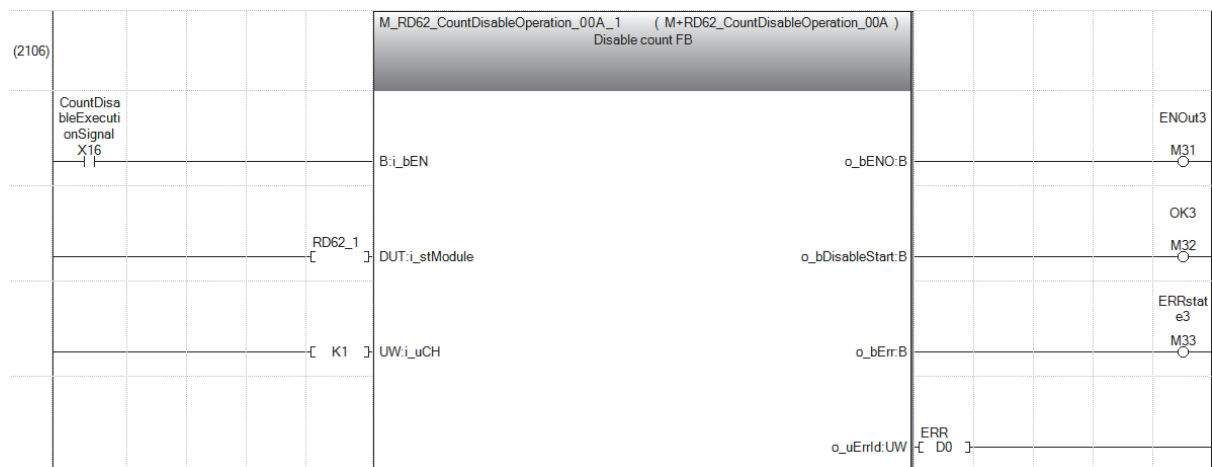



- When using the latch counter function

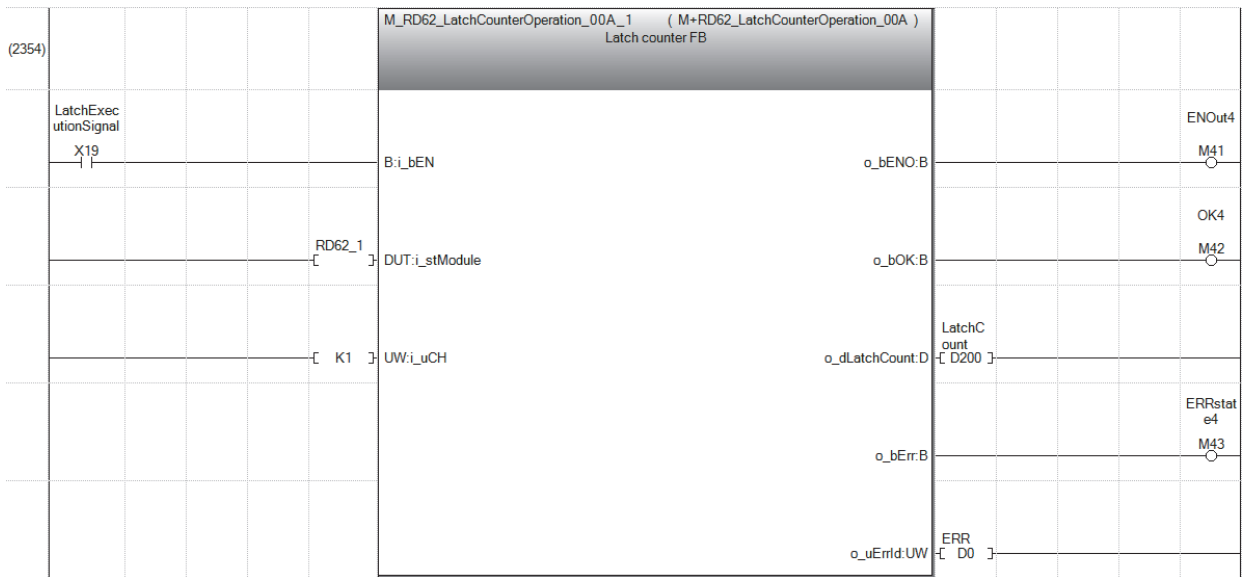

- When using the sampling counter function

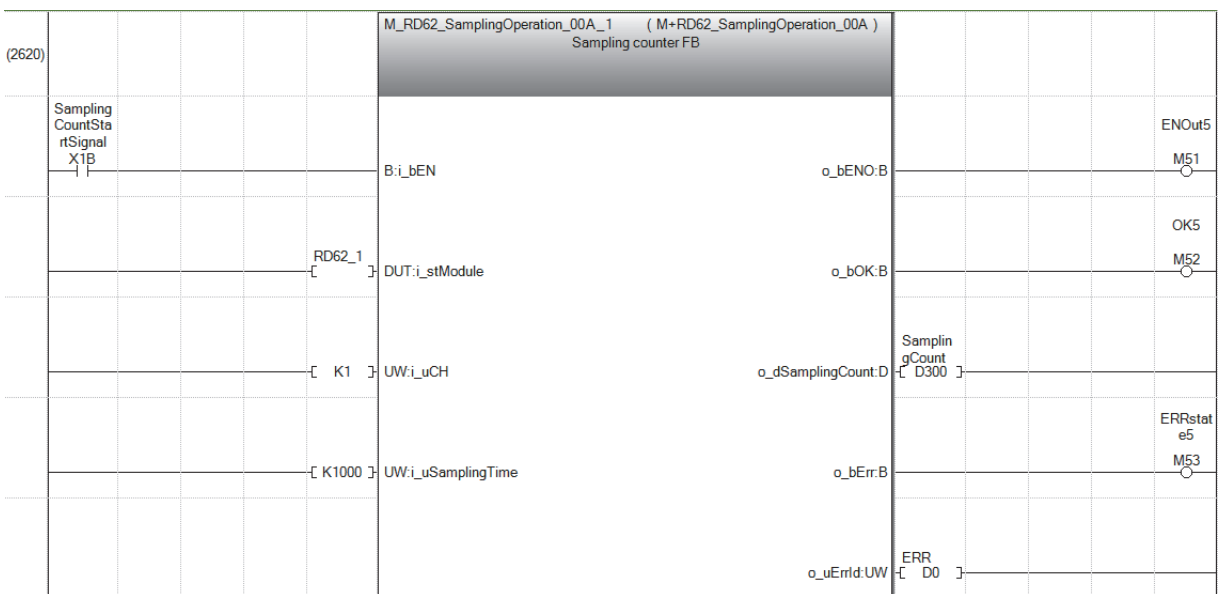

- When using the cycle pulse counter function

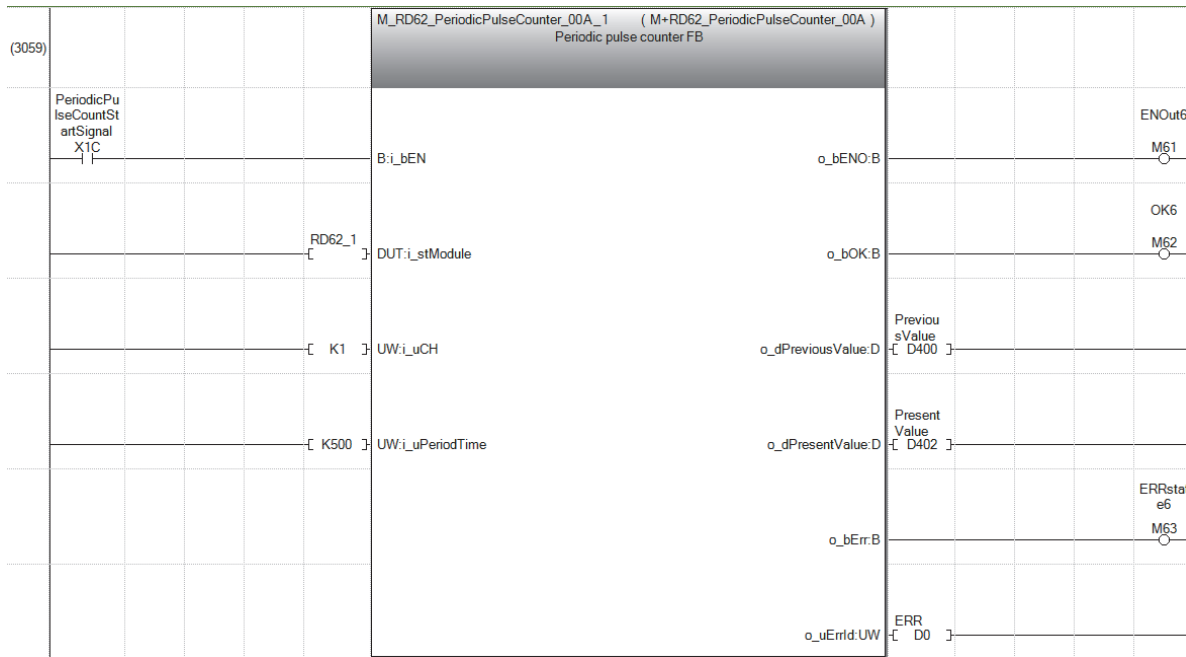

### Program example for pulse measurement mode

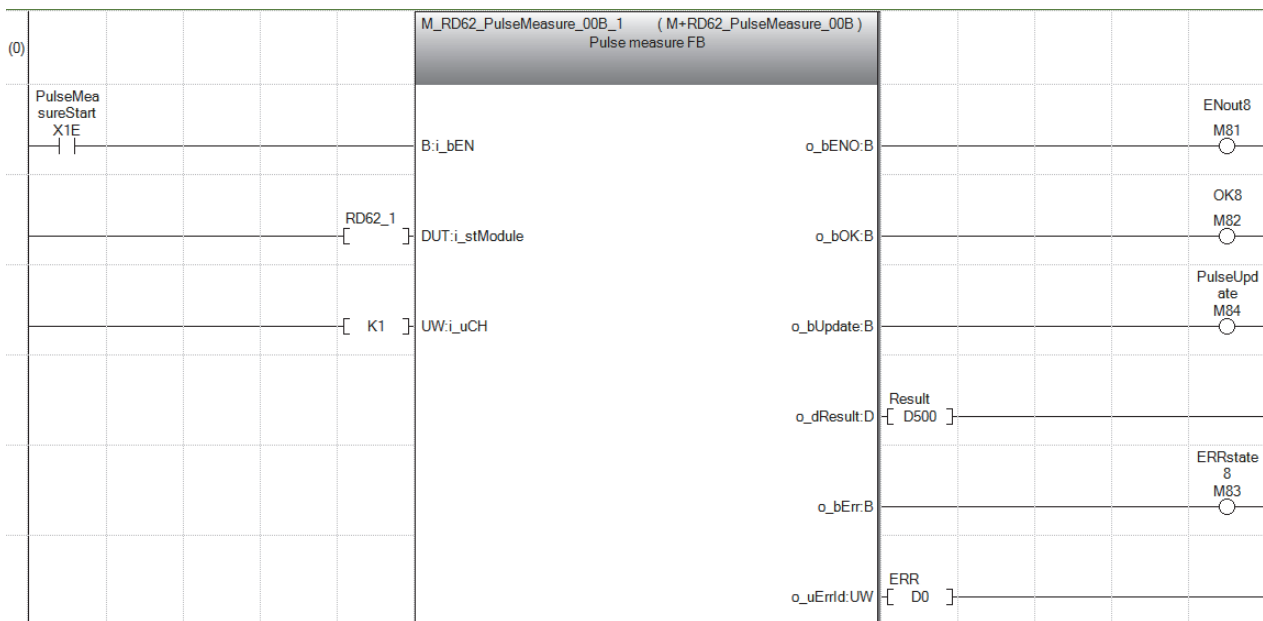

## Program example for PWM output mode

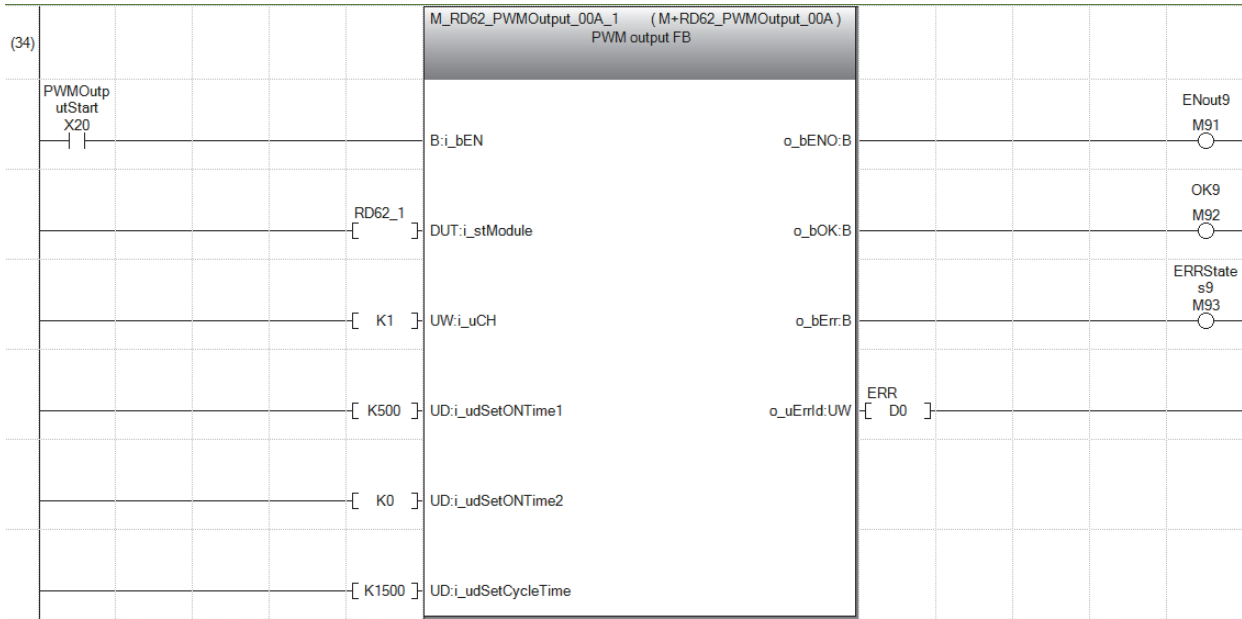

# APPENDIX

## Appendix 1 External Dimensions

This section describes the external dimensions of the high-speed counter module.

### RD62P2, RD62P2E, RD62D2

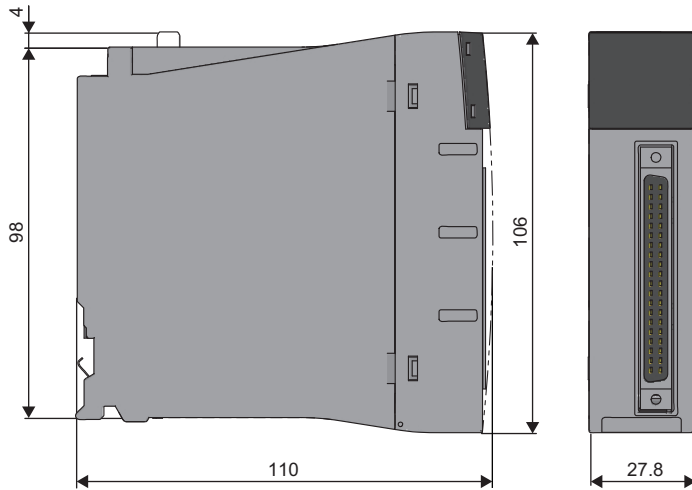

(Unit: mm)

# MEMO

---

A

# INDEX

---

## C

---

Coincidence detection interrupt function . . . . .	23
Coincidence output function . . . . .	23
Connectors for external devices . . . . .	28
Count disable function . . . . .	23
Counter function selection . . . . .	23
Cycle pulse counter function . . . . .	23

## E

---

Encoder . . . . .	33
External dimensions . . . . .	50

## I

---

Inter-module synchronization function . . . . .	23
---	----

## L

---

Latch counter function . . . . .	23
Linear counter function . . . . .	23

## P

---

Preset function . . . . .	23
Program examples . . . . .	43
Pulse count mode . . . . .	22
Pulse measurement function . . . . .	23
Pulse measurement mode . . . . .	22
PWM output function . . . . .	23
PWM output mode . . . . .	22

## R

---

Ring counter function. . . . .	23
--------------------------------	----

## S

---

Sampling counter function . . . . .	23
Signal layout. . . . .	29

# MEMO

---

# REVISIONS

\*The manual number is given on the bottom left of the back cover.

Revision date	*Manual number	Description
June 2014	SH(NA)-081239ENG-A	First edition
July 2014	SH(NA)-081239ENG-B	Error correction
January 2015	SH(NA)-081239ENG-C	■Added function Online module change ■Added or modified parts RELEVANT MANUALS, Chapter 1, 3, Section 5.1
March 2016	SH(NA)-081239ENG-D	■Added or modified parts RELEVANT MANUALS, Section 2.1, 5.1, 5.2, 6.2, Appendix 1

Japanese manual number: SH-081238-D

This manual confers no industrial property rights of any other kind, nor does it confer any patent licenses. Mitsubishi Electric Corporation cannot be held responsible for any problems involving industrial property rights which may occur as a result of using the contents noted in this manual.

© 2014 MITSUBISHI ELECTRIC CORPORATION



# WARRANTY

---

Please confirm the following product warranty details before using this product.

## **1. Gratis Warranty Term and Gratis Warranty Range**

If any faults or defects (hereinafter "Failure") found to be the responsibility of Mitsubishi occurs during use of the product within the gratis warranty term, the product shall be repaired at no cost via the sales representative or Mitsubishi Service Company.

However, if repairs are required onsite at domestic or overseas location, expenses to send an engineer will be solely at the customer's discretion. Mitsubishi shall not be held responsible for any re-commissioning, maintenance, or testing on-site that involves replacement of the failed module.

[Gratis Warranty Term]

The gratis warranty term of the product shall be for one year after the date of purchase or delivery to a designated place. Note that after manufacture and shipment from Mitsubishi, the maximum distribution period shall be six (6) months, and the longest gratis warranty term after manufacturing shall be eighteen (18) months. The gratis warranty term of repair parts shall not exceed the gratis warranty term before repairs.

[Gratis Warranty Range]

- (1) The range shall be limited to normal use within the usage state, usage methods and usage environment, etc., which follow the conditions and precautions, etc., given in the instruction manual, user's manual and caution labels on the product.
- (2) Even within the gratis warranty term, repairs shall be charged for in the following cases.
  1. Failure occurring from inappropriate storage or handling, carelessness or negligence by the user. Failure caused by the user's hardware or software design.
  2. Failure caused by unapproved modifications, etc., to the product by the user.
  3. When the Mitsubishi product is assembled into a user's device, Failure that could have been avoided if functions or structures, judged as necessary in the legal safety measures the user's device is subject to or as necessary by industry standards, had been provided.
  4. Failure that could have been avoided if consumable parts (battery, backlight, fuse, etc.) designated in the instruction manual had been correctly serviced or replaced.
  5. Failure caused by external irresistible forces such as fires or abnormal voltages, and Failure caused by force majeure such as earthquakes, lightning, wind and water damage.
  6. Failure caused by reasons unpredictable by scientific technology standards at time of shipment from Mitsubishi.
  7. Any other failure found not to be the responsibility of Mitsubishi or that admitted not to be so by the user.

## **2. Onerous repair term after discontinuation of production**

- (1) Mitsubishi shall accept onerous product repairs for seven (7) years after production of the product is discontinued. Discontinuation of production shall be notified with Mitsubishi Technical Bulletins, etc.
- (2) Product supply (including repair parts) is not available after production is discontinued.

## **3. Overseas service**

Overseas, repairs shall be accepted by Mitsubishi's local overseas FA Center. Note that the repair conditions at each FA Center may differ.

## **4. Exclusion of loss in opportunity and secondary loss from warranty liability**

Regardless of the gratis warranty term, Mitsubishi shall not be liable for compensation to:

- (1) Damages caused by any cause found not to be the responsibility of Mitsubishi.
- (2) Loss in opportunity, lost profits incurred to the user by Failures of Mitsubishi products.
- (3) Special damages and secondary damages whether foreseeable or not, compensation for accidents, and compensation for damages to products other than Mitsubishi products.
- (4) Replacement by the user, maintenance of on-site equipment, start-up test run and other tasks.

## **5. Changes in product specifications**

The specifications given in the catalogs, manuals or technical documents are subject to change without prior notice.

# TRADEMARKS

---

The company names, system names and product names mentioned in this manual are either registered trademarks or trademarks of their respective companies.

In some cases, trademark symbols such as <sup>™</sup> or <sup>®</sup> are not specified in this manual.



SH(NA)-081239ENG-D(1603)MEE

MODEL: RD62-U-IN-E

MODEL CODE: 13JX05

## **mitsubishi electric corporation**

HEAD OFFICE : TOKYO BUILDING, 2-7-3 MARUNOUCHI, CHIYODA-KU, TOKYO 100-8310, JAPAN  
NAGOYA WORKS : 1-14, YADA-MINAMI 5-CHOME, HIGASHI-KU, NAGOYA, JAPAN

When exported from Japan, this manual does not require application to the  
Ministry of Economy, Trade and Industry for service transaction permission.

Specifications subject to change without notice.